



JLab12 (R.N. & R.L.: Marco Contalbrigo)

- Nucleon structure and spin physics
- Transverse momentum phenomena (TMDs) & 3D imaging
- GPDs & EM Form Factors of the nucleon

M. Contalbrigo elected Chair of the JLab User Organization
(1600 users from US and all over the World)

M. Contalbrigo PI of the CLAS12 RICH detector

M. Contalbrigo contact person for RGH group of experiment
with transversely polarized target

Jlab12 Italia (R.N. & R.L. M. Contalbrigo)

Hall A – Spettrometri ad alta risoluzione e un nuovo rivelatore multipurpose a grande accettazione

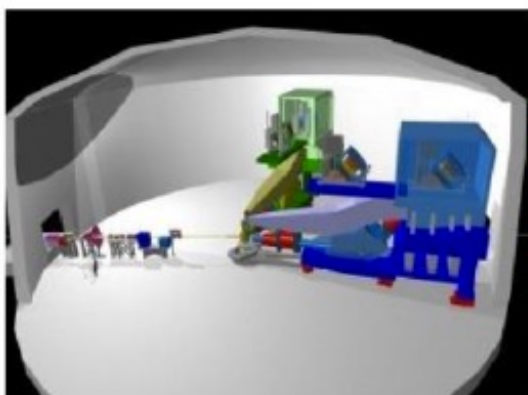

short range correlations, fattori di forma e nuovi esperimenti : SOLID, MOELLER, SBS

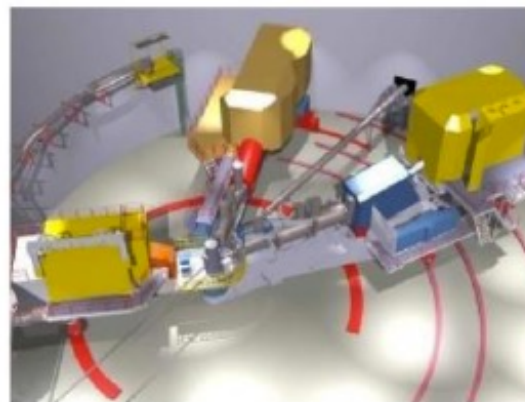

Hall C – Super High Momentum Spectrometer (SHMS)

Determinazione precisa delle proprietà dei q di valenza nei nucleoni e nei nuclei

Hall D – Rivelatore GLUEx per esperimenti di fotoproduzione

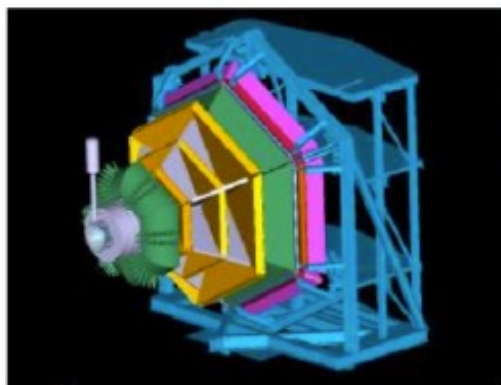

Hall B – Rivelatore a grande accettazione CLAS12 for misure a grande luminosità ($10^{35}\text{cm}^{-2}\text{s}^{-1}$)

Comprensione della struttura del nucleone via GPDs and TMDs e spettroscopia adronica

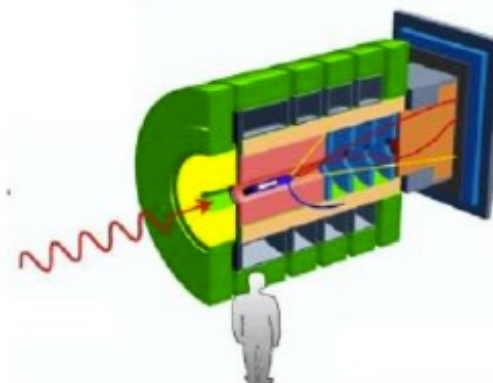

Le origini del confinamento attraverso lo studio dei mesoni ibridi

Hall-B: RICH installation completed
First run with a polarized target
Hall-A: Fully operational SBS spectrometer

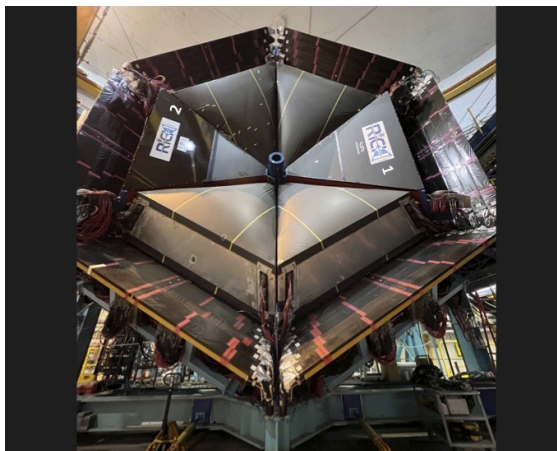

CLAS12: PRL 130 (2023) 21, 211902
First CLAS12 Measurement of DVCS Beam-Spin Asymmetries in the Extended Valence Region

The first CLAS12 measurement of the DVCS beam-spin asymmetry off unpolarized proton targets, greatly extends the x and Q^2 phase space beyond the existing data in the valence region with unprecedented statistical precision.

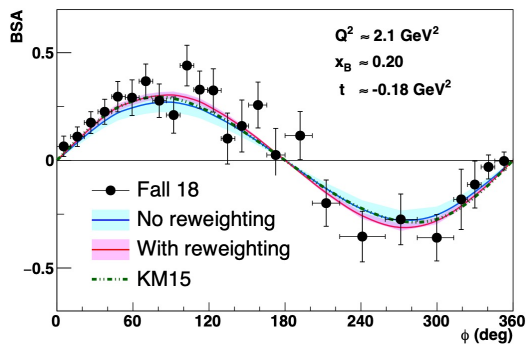

Hall-A: Nature 609 (2022) 41-46
Revealing short-range structure of the mirror nuclei ^3H and ^3He

Hall-A measurement of np/pp short-range correlation ratio in mirror nuclei ^3H and ^3He is an order of magnitude more precise than previous experiments, and finds a marked deviation from the near-total np dominance observed in heavy nuclei.

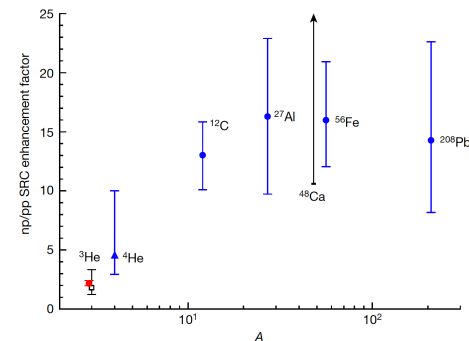

Dark matter: PRD 106 (2022) 072011
Dark matter search with DBX-mini experiment

The BDx-mini pilot experiment probed to be sensitive to the parameter space covered by some of the most sensitive experiments to date, and demonstrates the discovery potential of the next generation beam dump experiment planned at intense electron beam facilities.

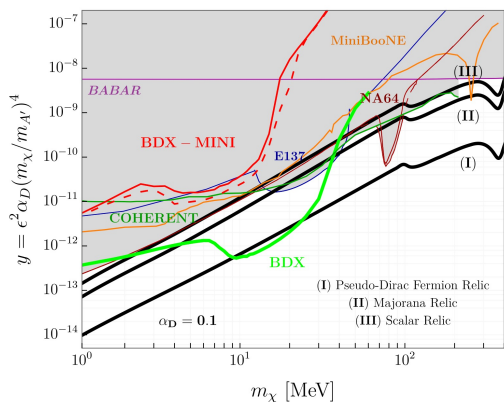

Hall-A: Nature Phys. 18 (2022) 1441-1446
Proton spin structure and generalized polarizabilities in the strong QCD regime

Hall-A measurement of the spin structure function g_2 accesses generalized polarizabilities that are fundamental quantities describing the nucleon's response to an external field, and benchmarks the Chiral perturbation theory predictions.

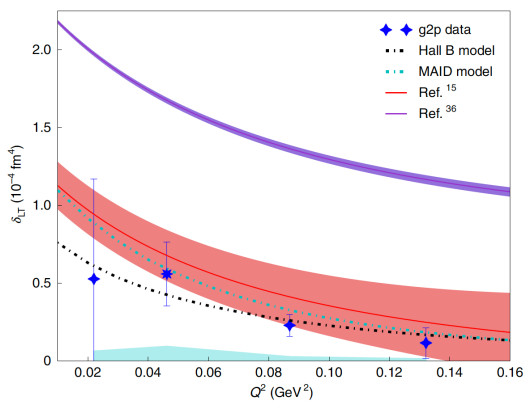

CREX: PRL 129 (2022) 042501
Precise determination of the neutral weak form factor of ^{48}Ca .

CREX has performed a precise determination of the neutron skin thickness of the ^{48}Ca nucleus. Together with the PREX measurement on ^{208}Pb , it provides constraints on the density dependence of the symmetry energy of nuclear matter.

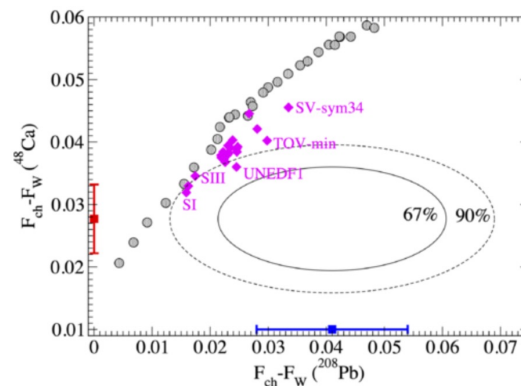

CLAS12 Experiment in Hall-B

12 GeV CEBAF

Beam current	90 μA
Beam polarization	85 %

Upgrade magnets
and power
supplies

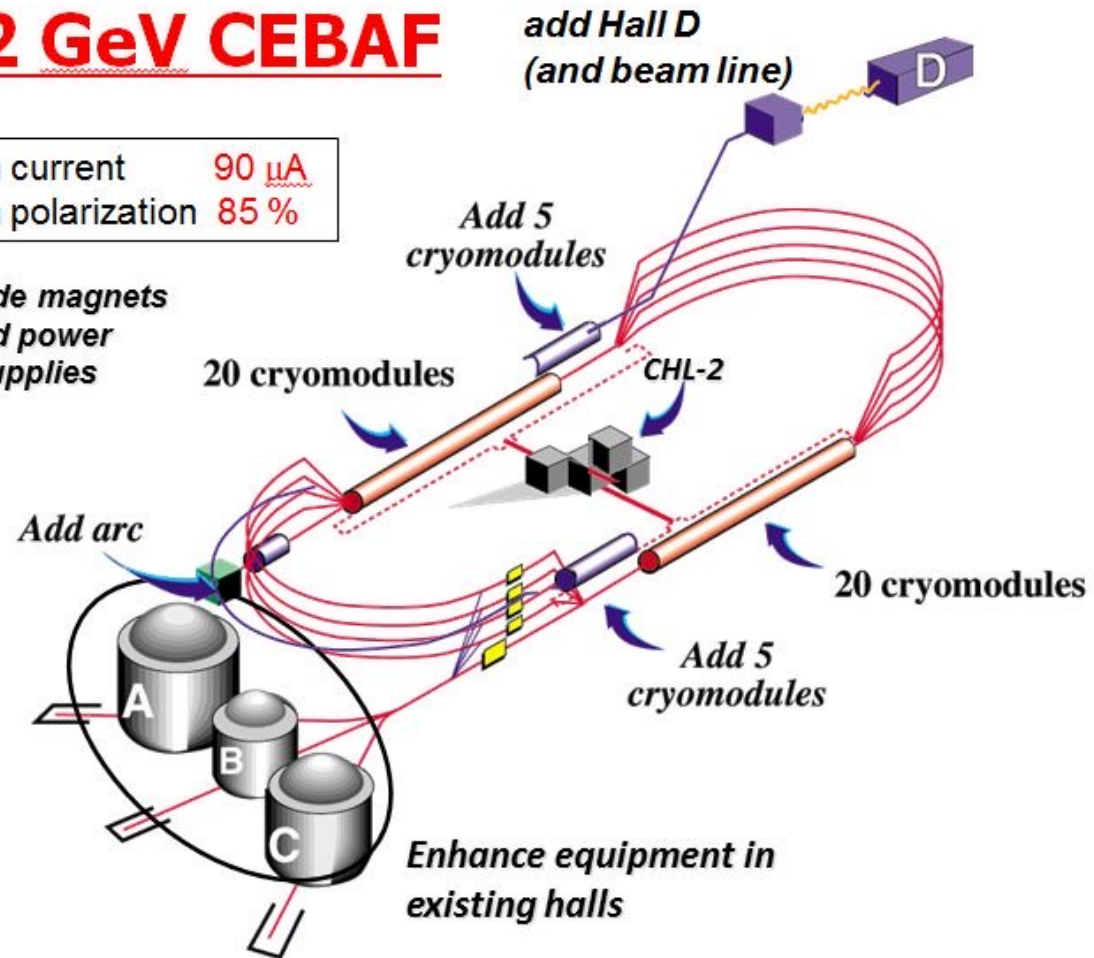

CLAS12 Experiment in Hall-B

12 GeV CEBAF

CLAS12 detector

- Lumi up to $10^{35} \text{ cm}^{-2} \text{ s}^{-1}$
- High polarized electron beams
- H and D polarized target
- Broad kinematic range
- Very good PID

Beam current	90 μA
Beam polarization	85 %

*Upgrade magnets
and power
supplies*

*add Hall D
(and beam line)*

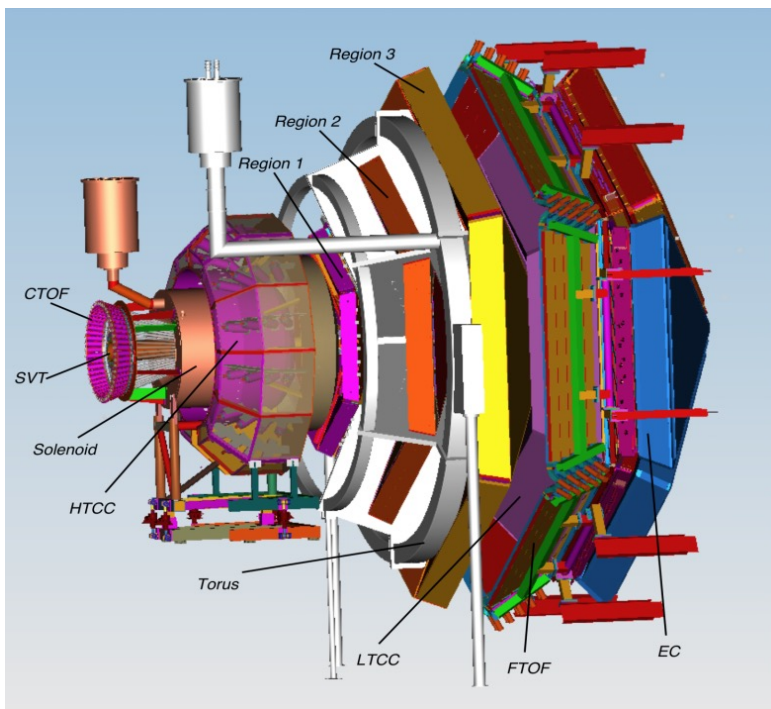
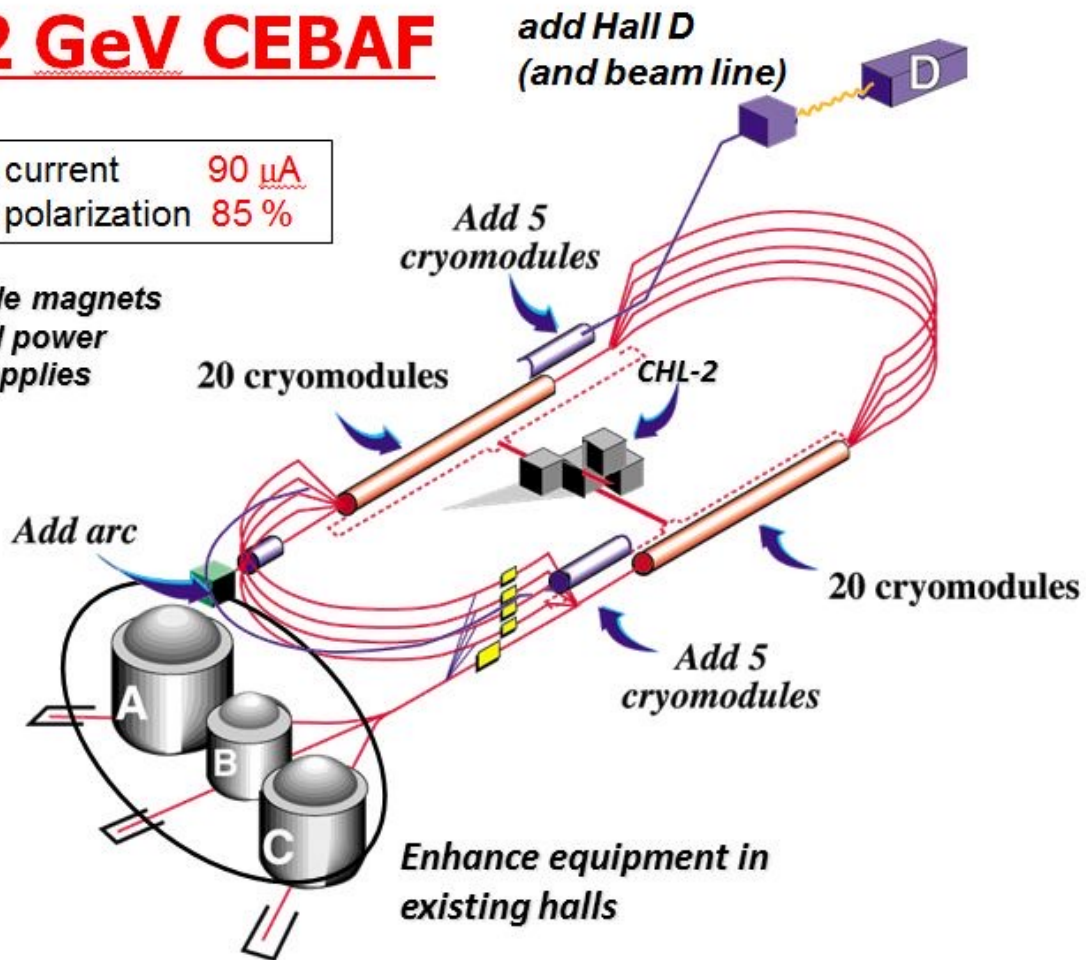

CLAS12 Experiment in Hall-B

12 GeV CEBAF

CLAS12 detector

- Lumi up to $10^{35} \text{ cm}^{-2} \text{ s}^{-1}$
- High polarized electron beams
- H and D polarized target
- Broad kinematic range
- Very good PID

Beam current	90 μA
Beam polarization	85 %

Upgrade magnets
and power
supplies

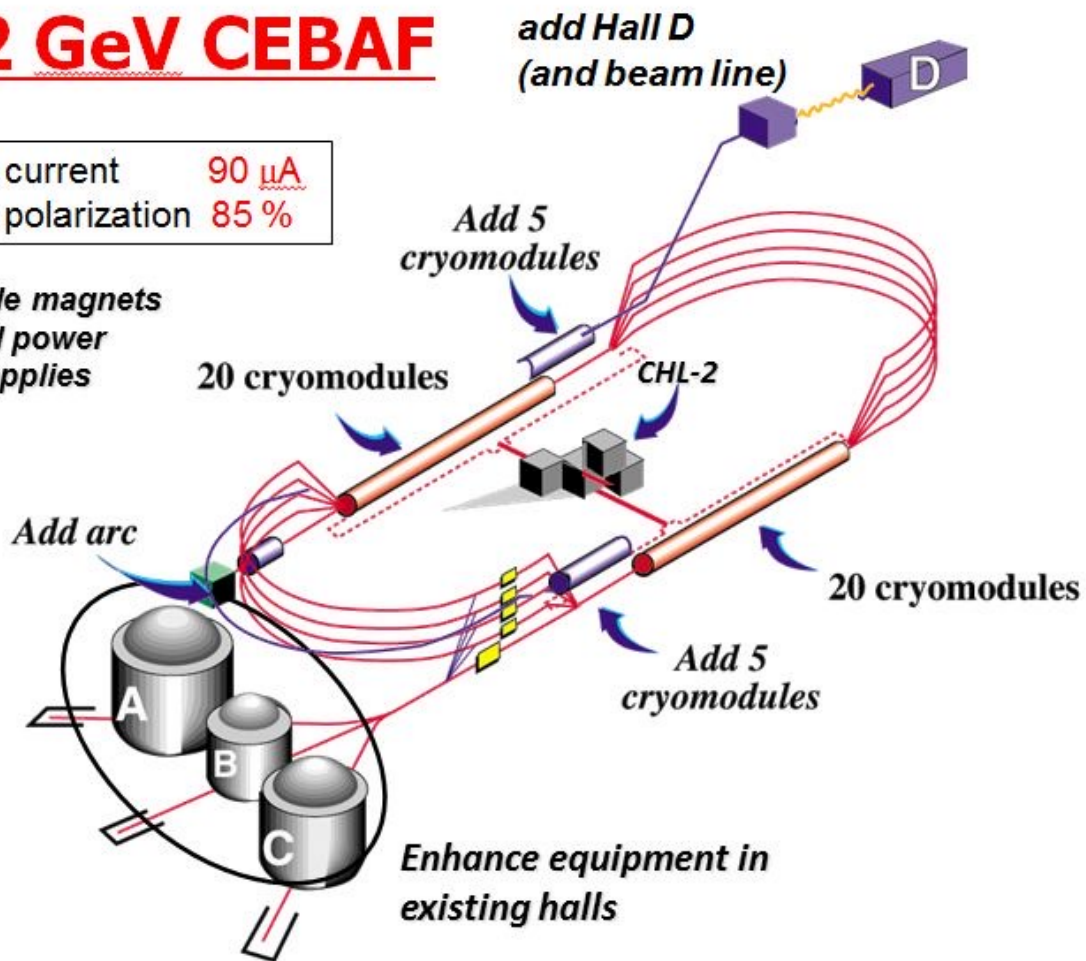
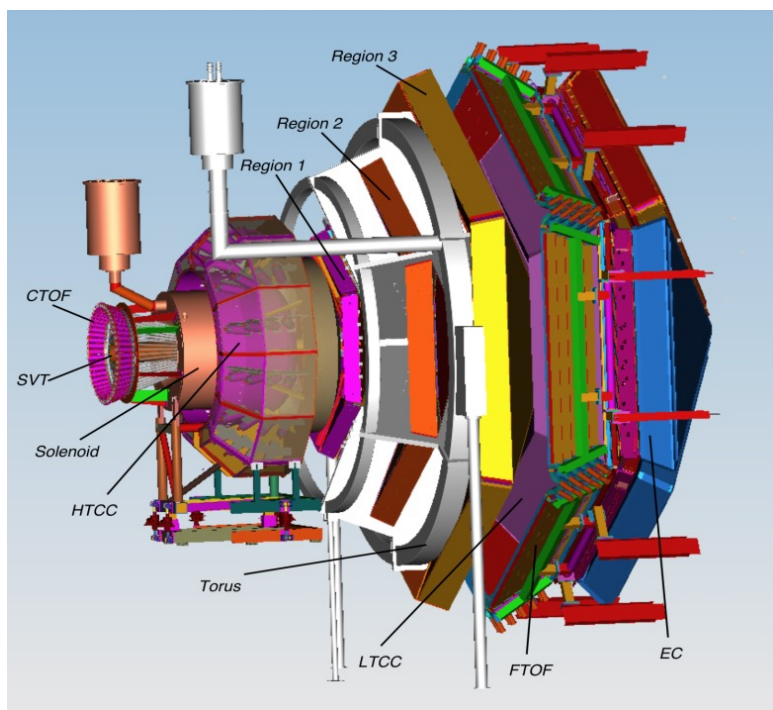

Physics program:

- Hadron spectroscopy
- Nuclear effects in hadronization
- **Nucleon structure (TMDs, GPDs)**

CLAS12 Experiment in Hall-B

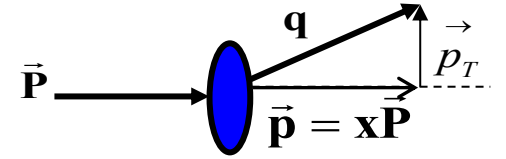
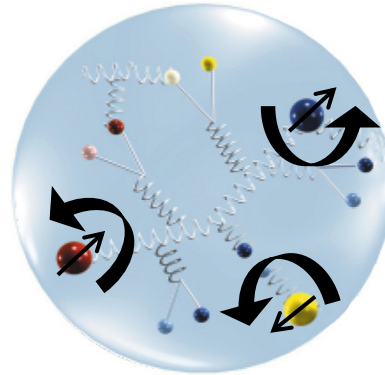
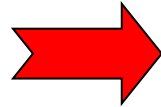
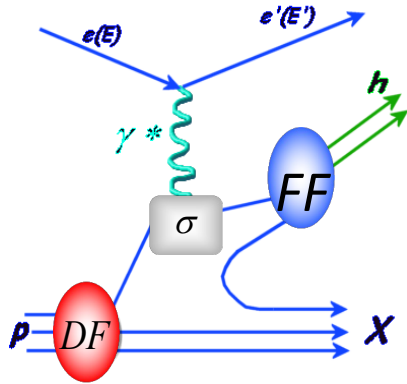

- TMDs depend on x and p_T
- Describe correlations between p_T and quark or nucleon spin (**spin-orbit correlations**)
- Provide a **3-dim picture** of the nucleon in momentum space (**nucleon tomography**)

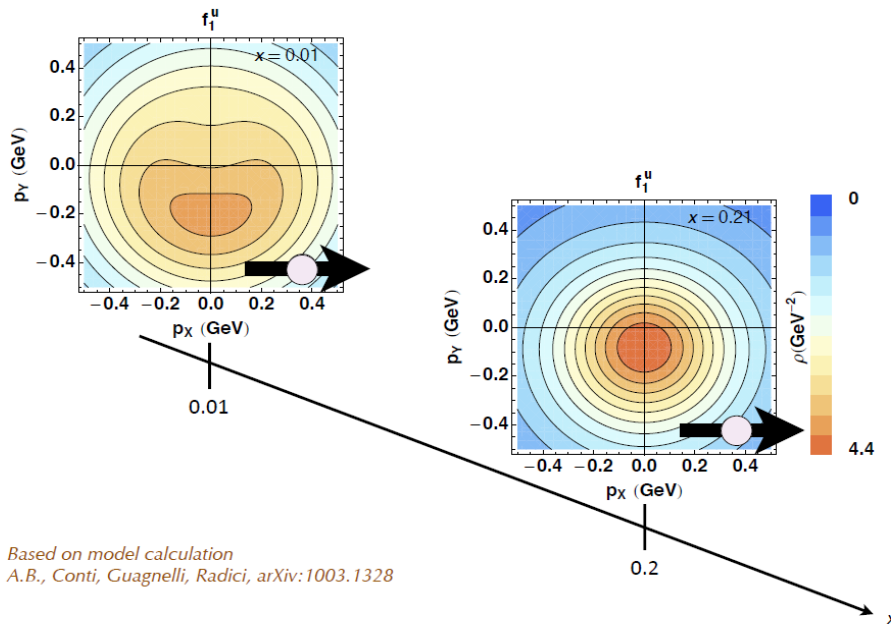

Based on model calculation
A.B., Conti, Guagnelli, Radici, arXiv:1003.1328

CLAS12 Experiment in Hall-B

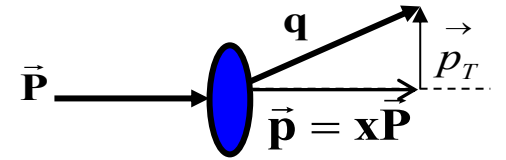
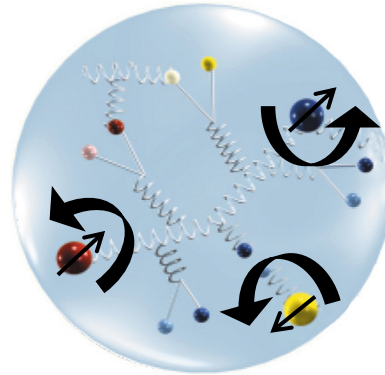
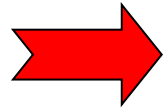
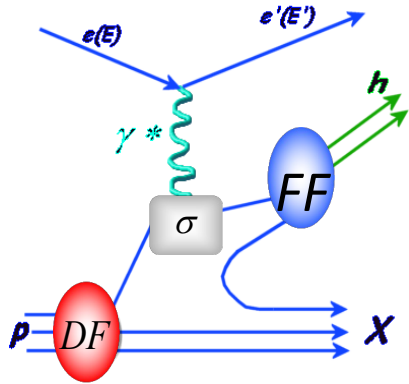

- TMDs depend on x and p_T
- Describe correlations between p_T and quark or nucleon spin (**spin-orbit correlations**)
- Provide a **3-dim picture** of the nucleon in momentum space (**nucleon tomography**)

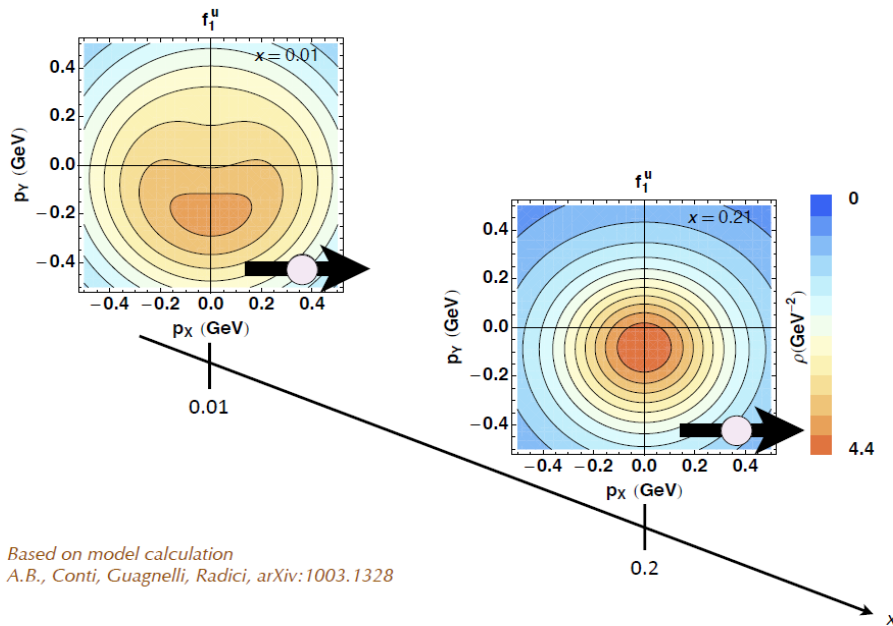

Based on model calculation
A.B., Conti, Guagnelli, Radici, arXiv:1003.1328

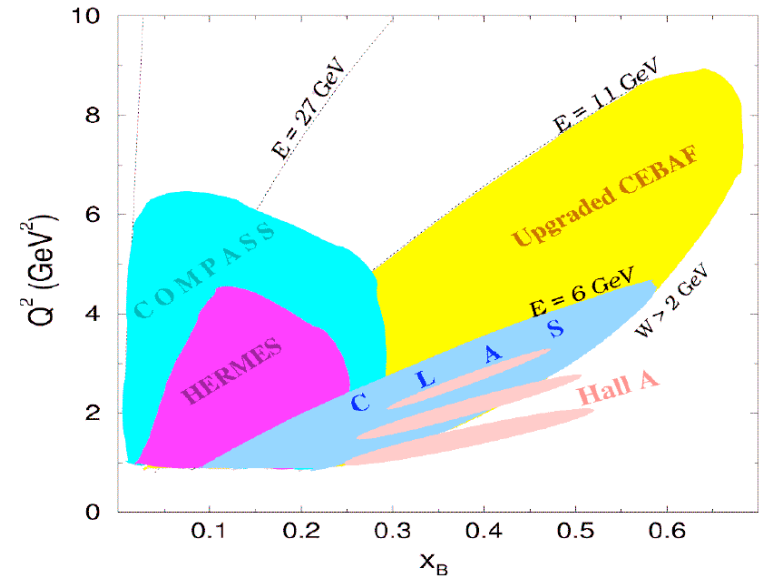

The RICH detector project (INFN)



Physics Program	Particle Identification Requirement
Internal nucleon dynamics	Flavour tagging
Quark hadronisation in nuclear medium	Constraining models
Spectroscopy	Rare processes

RICH goal:

$\pi/K/p$ separation of $\sim 4 \sigma$ up to 8 GeV/c
for a pion rejection factor $\sim 1:500$

Completed with 2nd module in June 2022

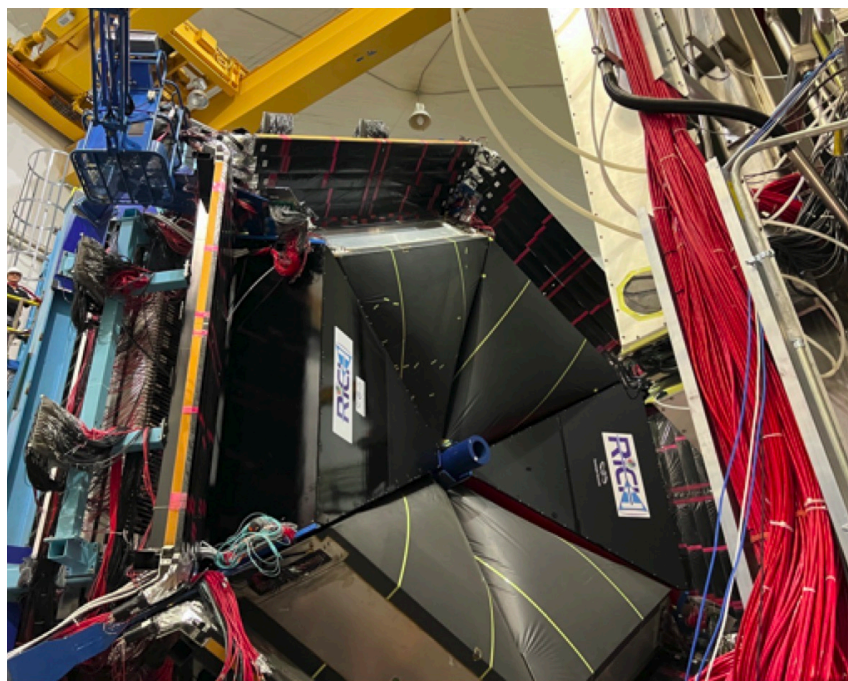

INSTITUTIONS
INFN (Italy) Bari, Ferrara, Genova, L.Frascati, Roma/ISS
Jefferson Lab (Newport News, USA)
Argonne National Lab (Argonne, USA)
Duquesne University (Pittsburgh, USA)
George Washington University (USA)
Glasgow University (Glasgow, UK)
J. Gutenberg Universitat Mainz (Mainz, Germany)
Kyungpook National University, (Daegu, Korea)
University of Connecticut (Storrs, USA)
UTFSM (Valparaiso, Chile)

The RICH Front-End electronics

Compact and modular electronics to readout multi-anode PMTs

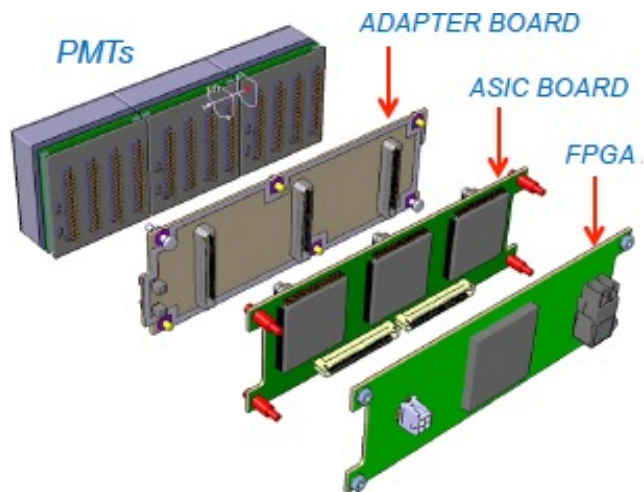

FPGA Board (JLab)



ASIC Board (Ferrara)

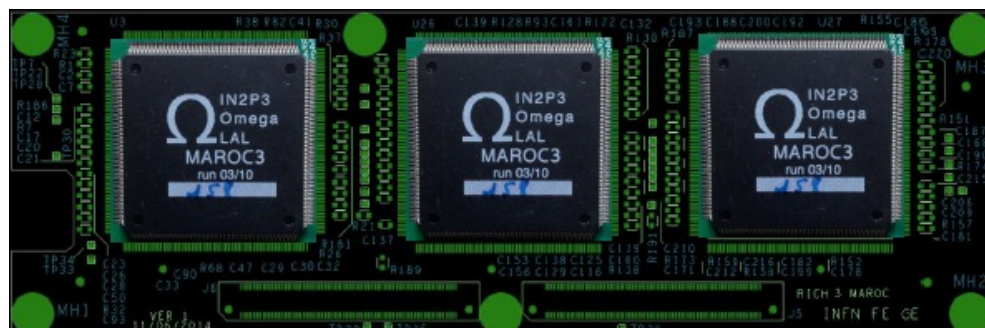

Adopted by other experiments:
GlueX, SOLID, EIC R&D...

Adapted to different sensors:
Multi-anode PMT H12700, H13700
SiPM array S12642, H13361

Developed thanks to Roberto M., L. Barion

The RICH Reconstruction

Completed for the CLAS pass-2 data reprocessing (started in spring 2023)
Single-photon pattern recognition based on space and time

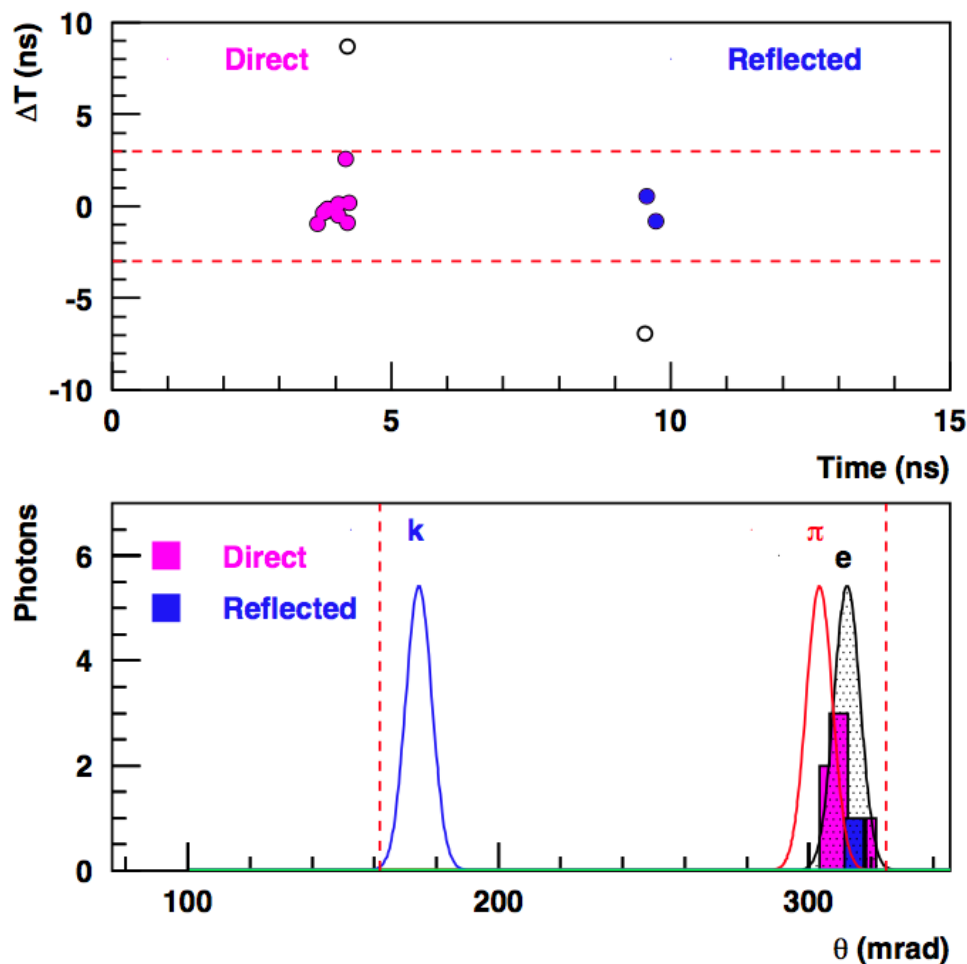
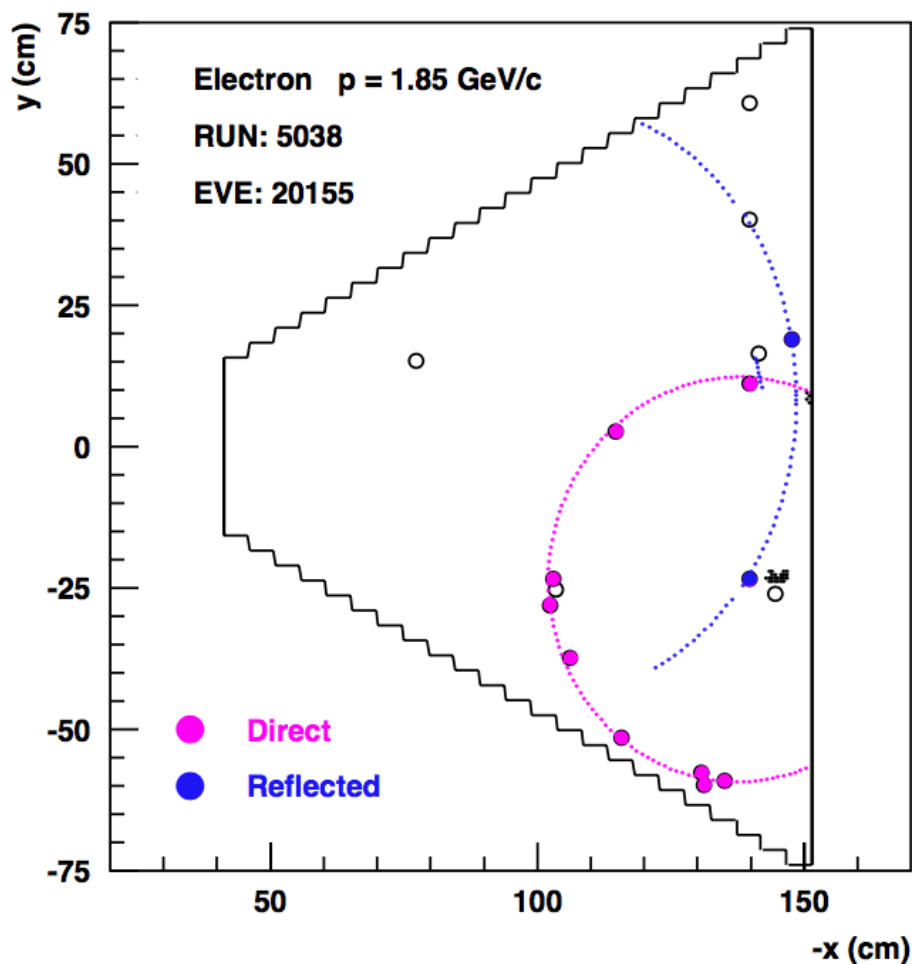

The RICH Reconstruction

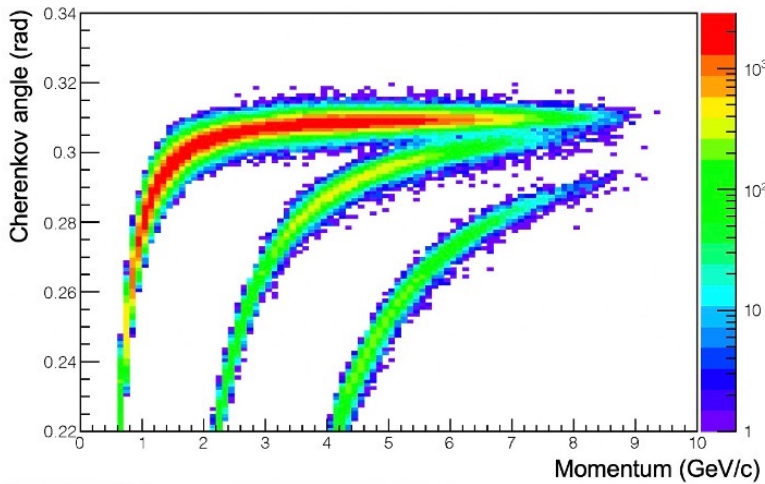
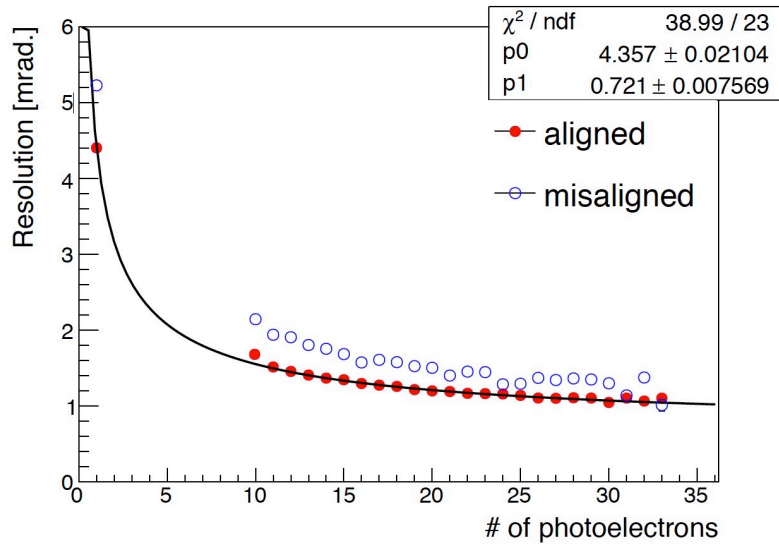

Check with semi-inclusive physics channel $ep \rightarrow eh^+X$

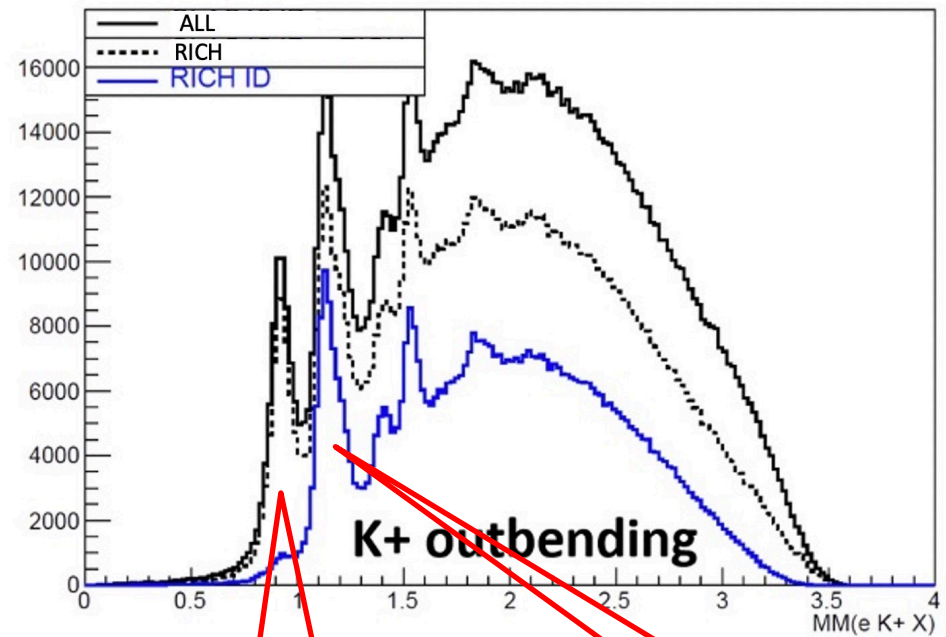

$ep \rightarrow e\pi^+n$
background

$ep \rightarrow eK^+\Lambda$
signal

The Transverse target

Internal Target

To maintain transverse spin polarization within the CLAS12 solenoid and preserve wide acceptance for the final-state particles, new magnetic solutions are required.

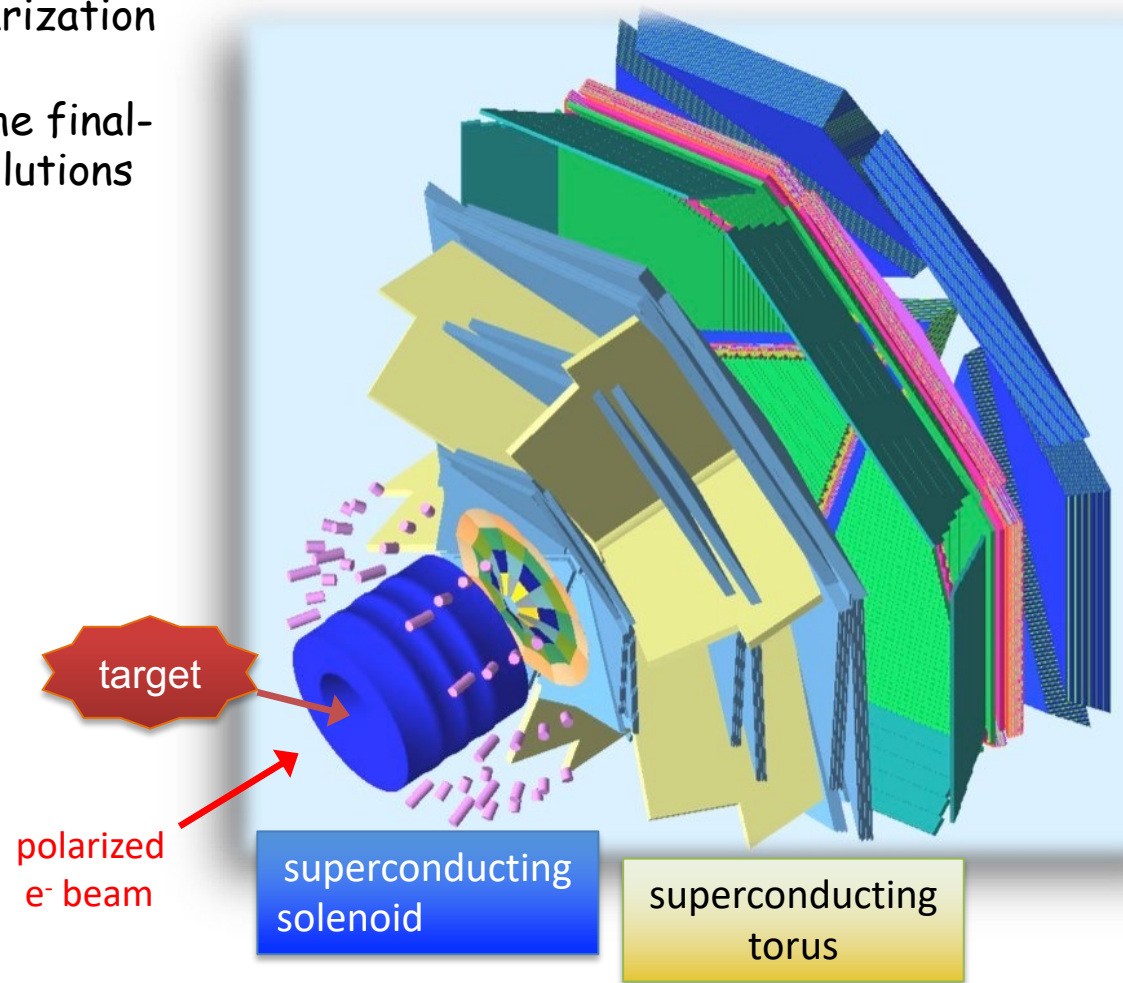

The Transverse target

Internal Target

To maintain transverse spin polarization within the CLAS12 solenoid and preserve wide acceptance for the final-state particles, new magnetic solutions are required.

Tracking solenoid

- design up to 5 T longitudinal
- 4K L-He cryostat
- length 1500 mm

Transverse Target:

- high polarization
- d 25 mm - Length 10 mm
- transverse field up to 2 T

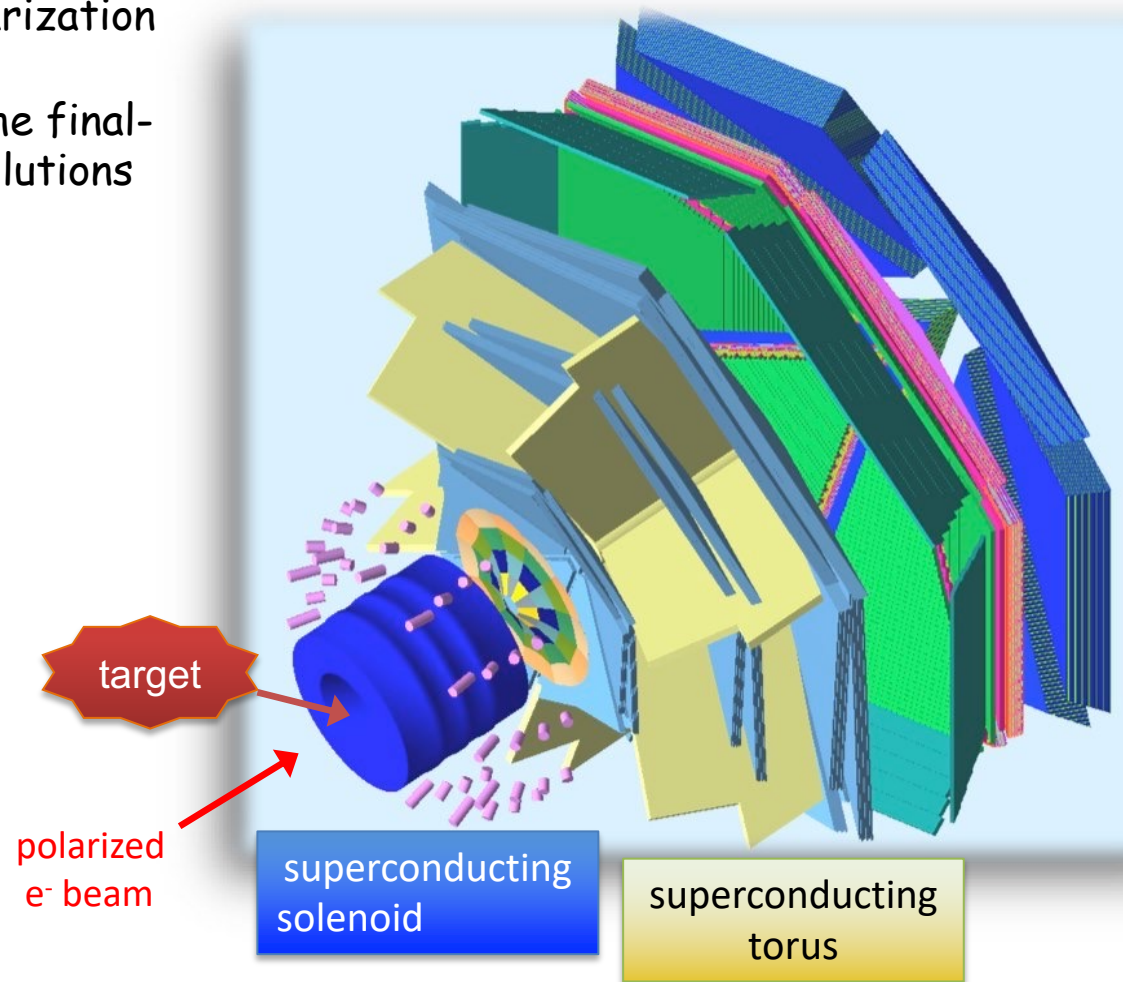

Transverse target: bulk transverse magnet

Alternative to the use of a massive 5 T magnet to increase acceptance (for recoil)

A hollow bulk superconductor is able to provide a transverse holding field inside, while adjusting its internal currents to shield any outside field, without the need of a current supply!

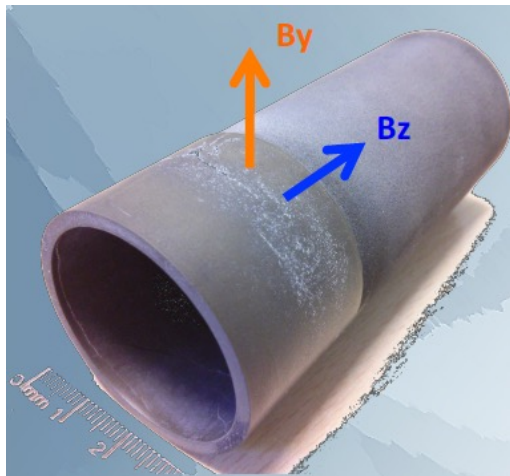

Bulk cylinder (MgB_2)

- longitudinal shield
- transverse magnetization

Features

- no current leads
- Cu free
- self tuning
- few mm thickness
- external magnet for magnetization

existing sample (courtesy of G. Giunchi)
diameter 39 mm
length 90 mm
thickness ~1 mm

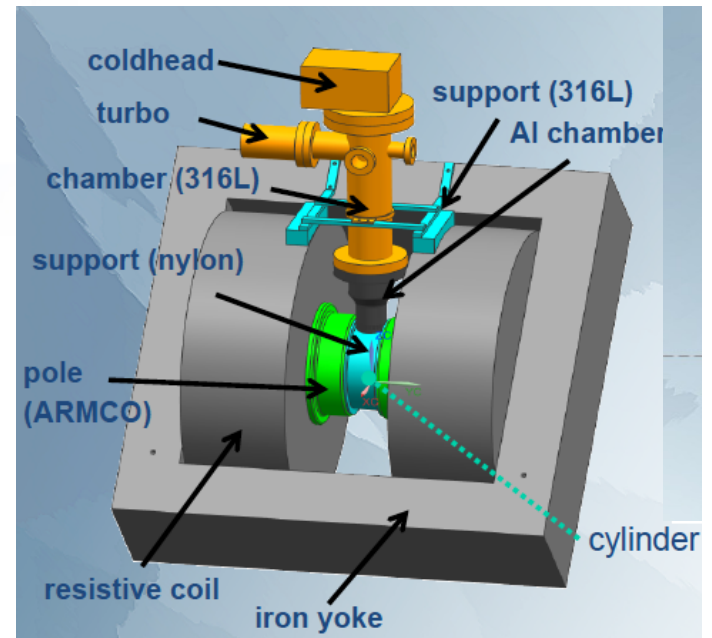

Transverse target: the Ferrara setup

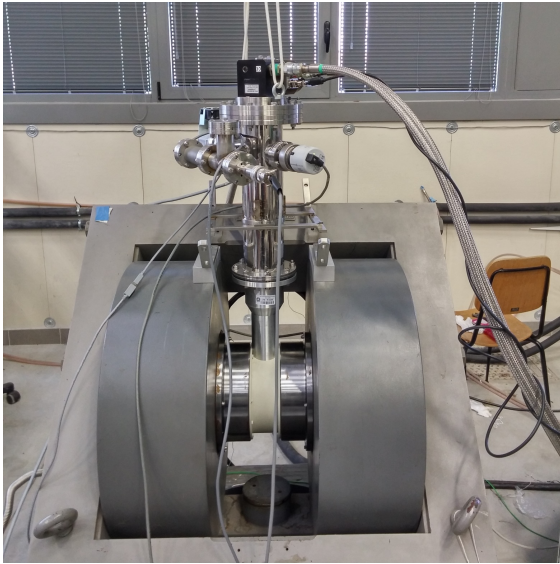

Dipole field frozen for days inside a MgB₂ cylinder:

- After cooling down the MgB₂ cylinder inside a dipole field of about 1T, the external field is zeroed and the dipole field at the center of the cylinder measured.
- With the decrease of the temperature below the transition point, an increasing fraction of the original field is trapped.
- At the minimum temperature of 12.8 K reachable by the setup, a field of about 940 mT is preserved for days, without any significant degradation

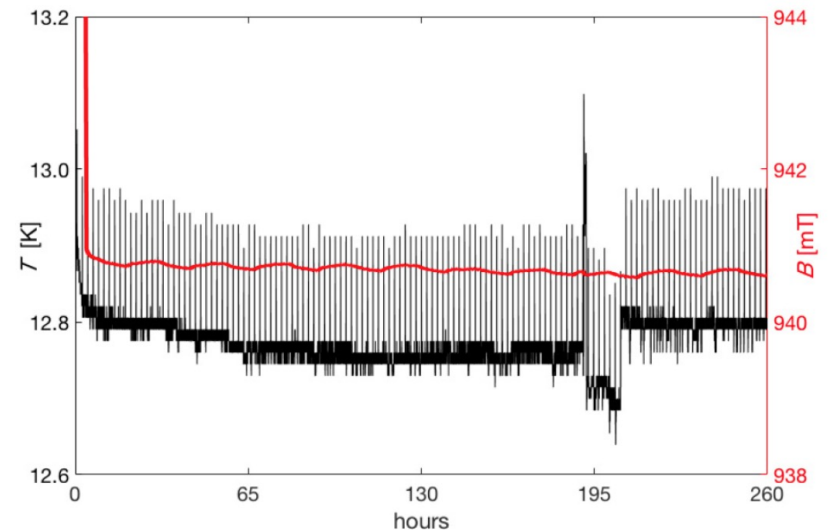
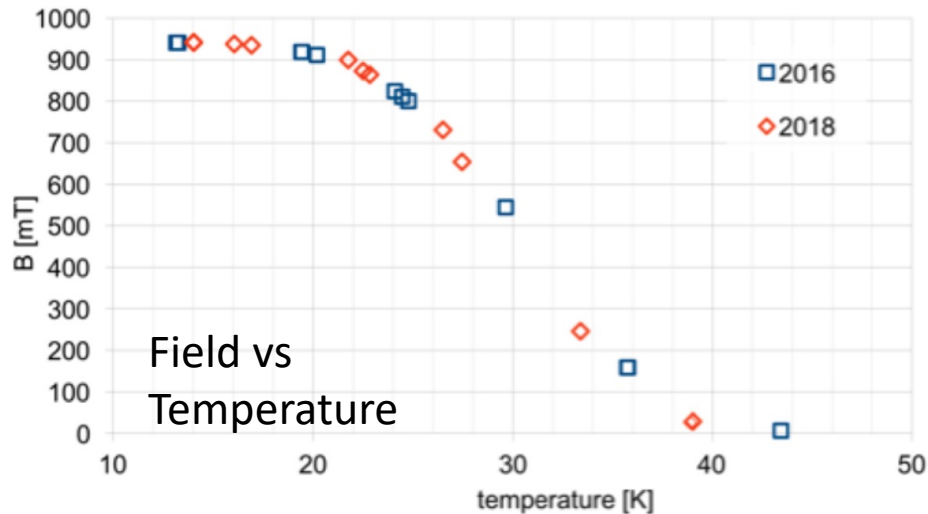

Transverse target: the new cryostat

New concept:
pre-conditioned bulk superconductor

- new cryostat
- new holder probe (6x)
- smart MgB₂ sample exchange

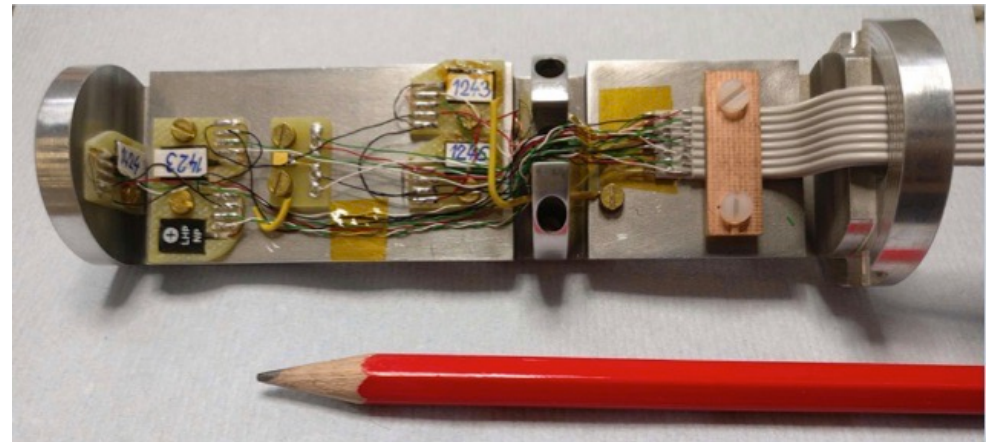

Magnetization @ 1 T

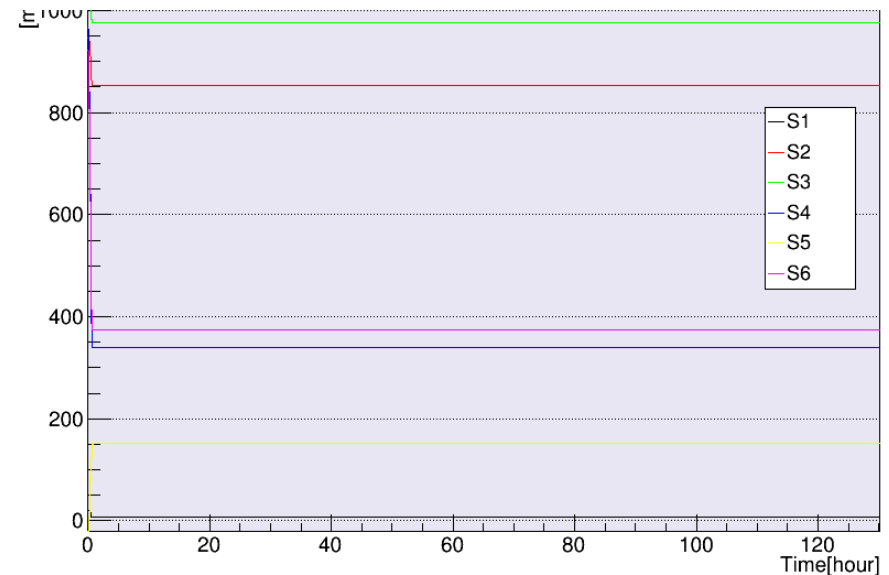

Developed thanks to L. Barion, M. Cavallina

Sintillating Fiber Detector

New potential application of the CLAS12 RICH Electronics reading SiPM

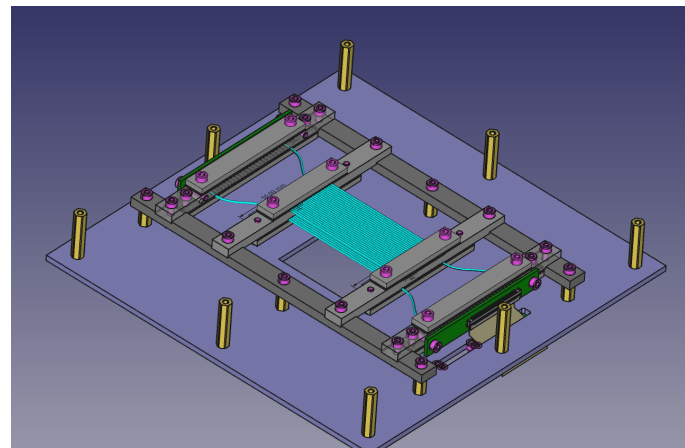
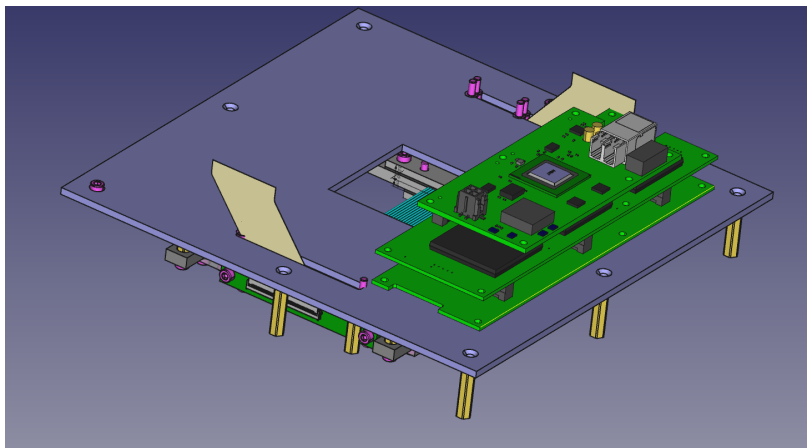

To be used as fast beam particle tracking with RICH prototypes

Potential use as recoil detector for CLAS12 – RGH (transversely polarized targets)

Developed thanks to L. Barion, M. Roberto, M. Cavallina

μ -Rwell @ CLAS12

Substitute first tracking chamber layer to increase the luminosity (x 2)

Develop a recoil detector for RGH- experiments with transversely polarized target

μ -Rwell technology features compactness, easy assembling, easy powering, intrinsic spark quenching
is new, only small prototypes have been tested \rightarrow require extensive R&D

@INFN: RM2 and G. Bencivenni
with support from other groups

2022: 10x10 cm² prototype readout
Compare 780 μ m vs 300 μ m pitch

2023: 50x50 cm² prototype

Study charge collection, time and spatial resolution

Requirements: $\sigma_s \sim 100$ mm

$\Delta t \sim 10$ ns

Eff > 95%

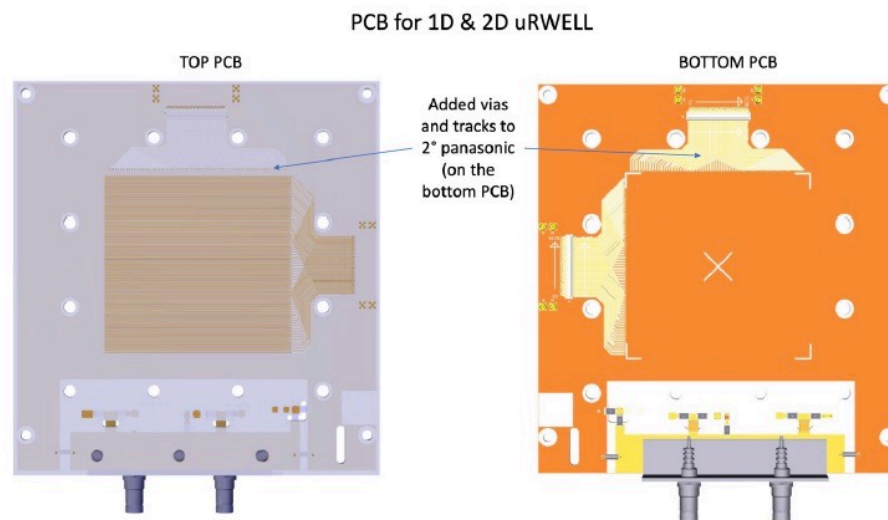

Mechanical stability study thanks to M. Melchiorri

Il gruppo di Ferrara @ JLab

Responsabilita':

- M. C.: responsabile locale e nazionale di JLab12
- M. C. : chair of the Jlab User Organization
- M. C.: contact person for the RGH experiments with transversely polarized target
- M. C. responsabile progetto RICH
- M. C. & L.P. Co-spokesperson di diverse proposte di esperimento (PAC34,37,38,39)

Contributi principali del gruppo:

- Data analysis
 - Data analysis on kaon SIDIS
- RICH detector
 - Reconstruction and alignment algorithms
- Magneti superconduttori
 - Configurazione magnetica per transverse target
 - Frozen field con magneti a bulk di superconduttore
 - Recoil detector design
- High-luminosity
 - Study micro-Rwell mechanical stability with light structure



EIC-NET (R.L.: Marco Contalbrigo)

- INFN Network for preliminary studies on the EIC project

M. Contalbrigo is dRICH detector subsystem lead
co-coordinator of the dRICH R&D EIC Program (eRD102)

A. Saputi is Contact Person for dRICH mechanics

dRICH: Dual-radiator RICH for the EIC hadron end-cap (project led by INFN)

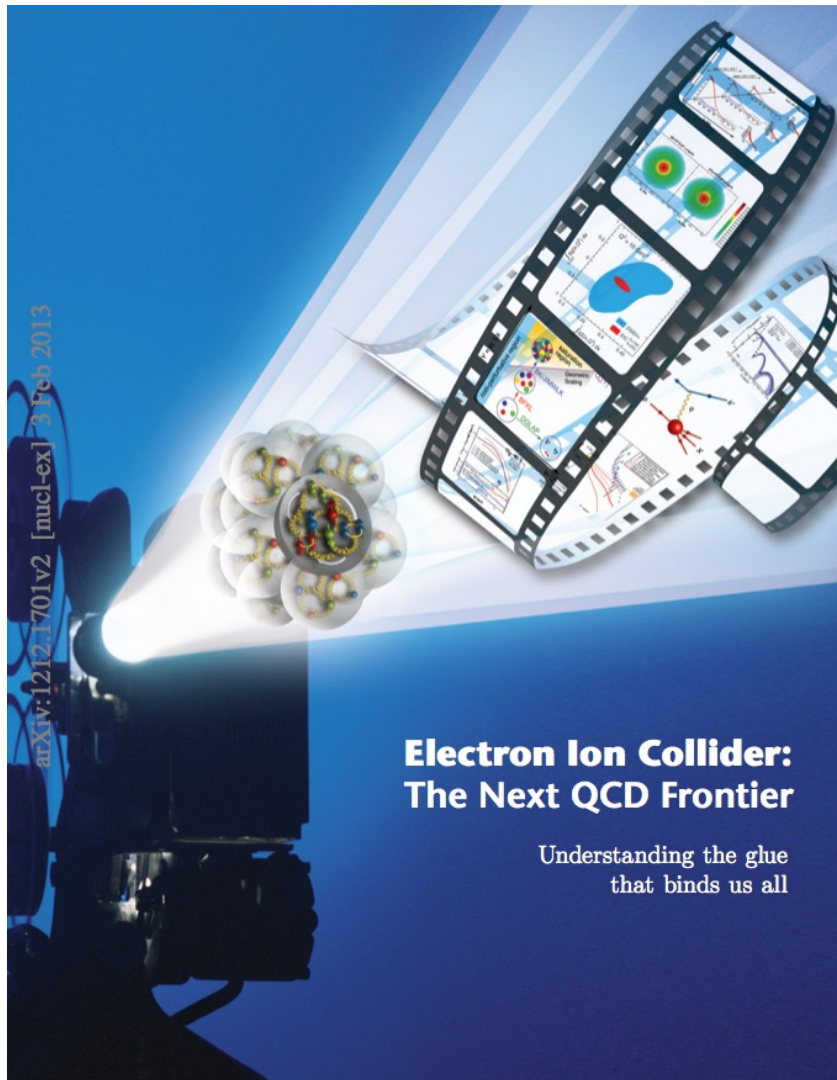

Electron Ion Collider:

Strong interest in Italian nuclear physics community (theory and experiment)

CD1 approval in June 2021

EPIC Coll. for 1st detector start in fall 2022

Detector subsystems defined in spring 2023

TDR expected at the end of 2024

CD2 & 3 expected in spring 2025
(start of construction)

INFN Ferrara leading the dRICH subsystem



EIC_NET: The dual RICH

Compact cost-effective solution for particle identification in the high-energy endcap at EIC

dRICH





BA, BO, CS, CT, FE ,
GE, LNF, LNS, RM2,
SA, TO, TS



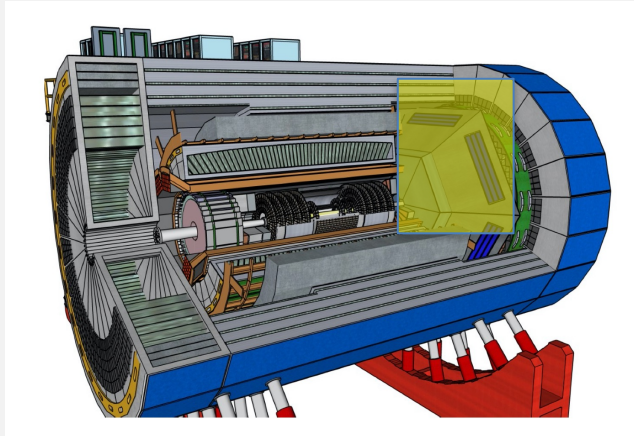

EPIC



EIC RICH Consortium

Univerza
v Ljubljani 

....



Background Expertise:

CLAS12 RICH

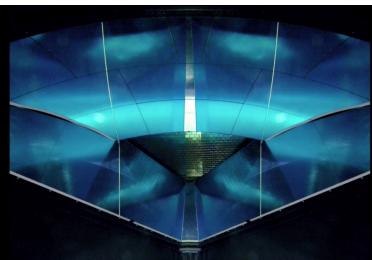

COMPASS RICH

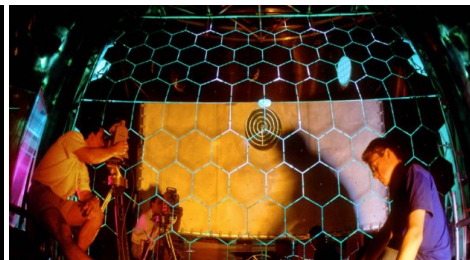

ALICE HMPID

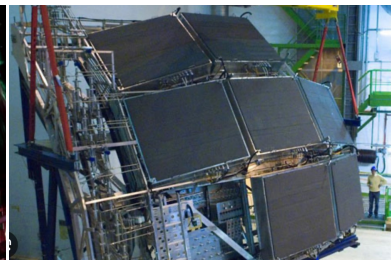

DARKSIDE

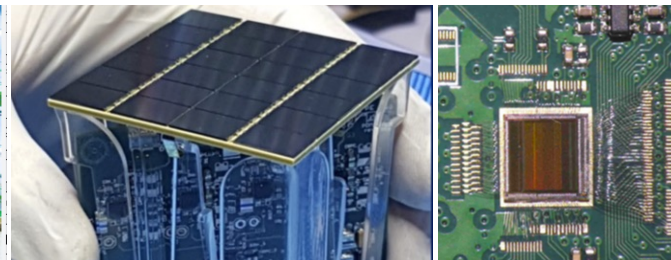

EIC_NET: dRICH Organization Chart

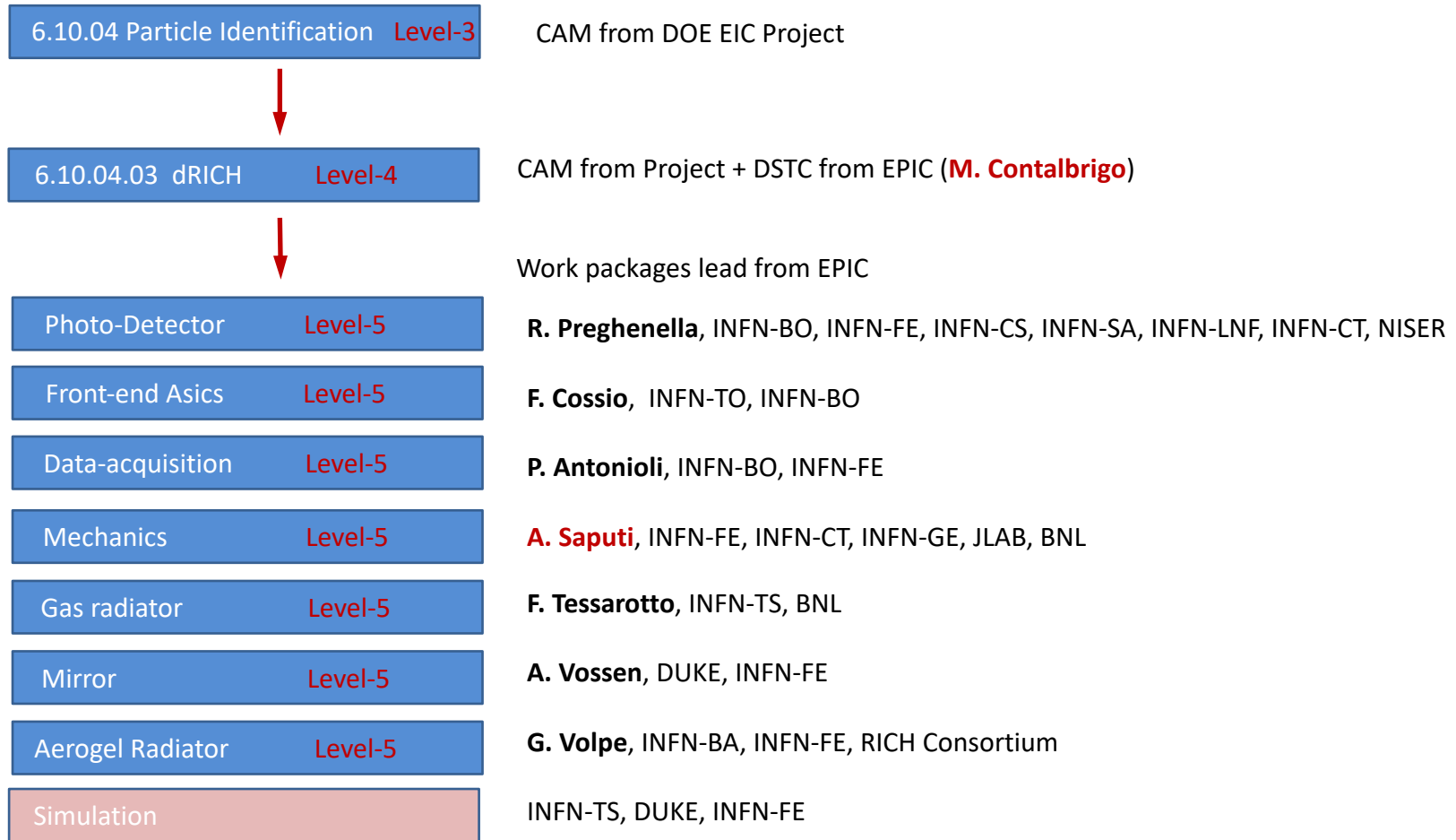

EIC_NET: Baseline Design

Main features

cover wide momentum range 3 - 50 GeV/c
work in high ($\sim 1\text{T}$) magnetic field
fit in a quite limited (for a gas RICH) space

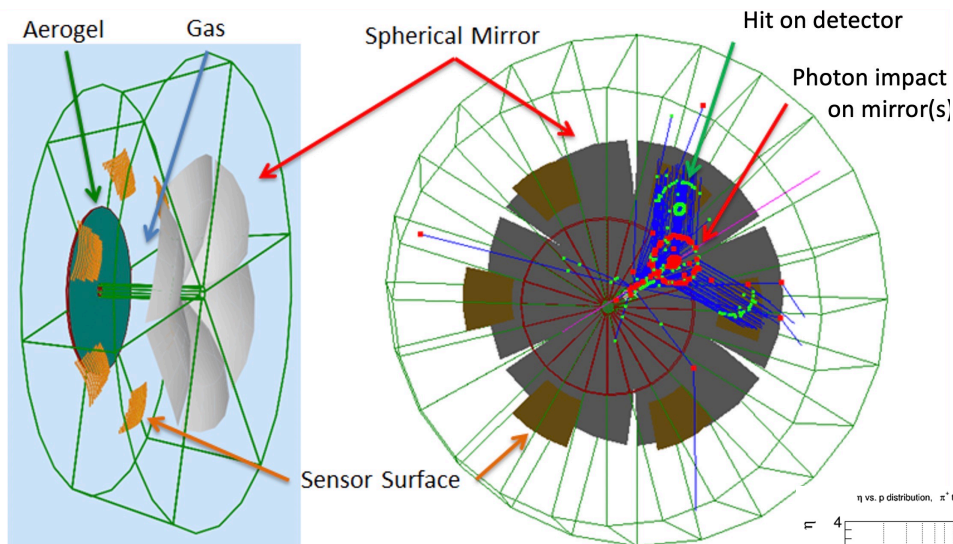

Essential for semi-inclusive physics
due to absence of kinematics constraints at event-level

dRICH: cost-effective compact solution

Radiators: Aerogel ($n_{\text{AERO}} \sim 1.02$) + Gas ($n_{\text{C}_2\text{F}_6} \sim 1.0008$)

Detector: $0.5 \text{ m}^2/\text{sector}$, $3 \times 3 \text{ mm}^2$ pixel \rightarrow SiPM option

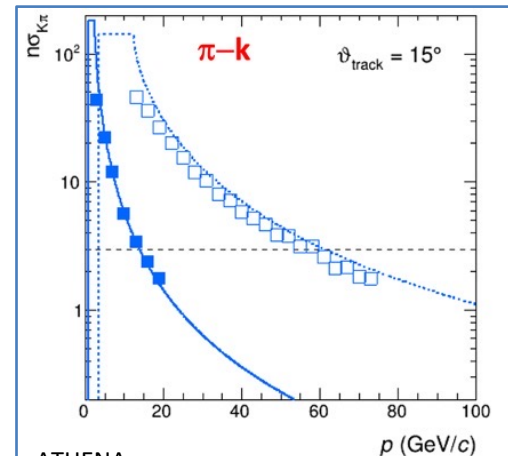
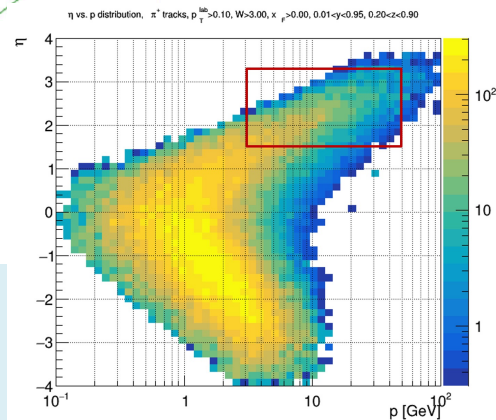

ATHERNA case

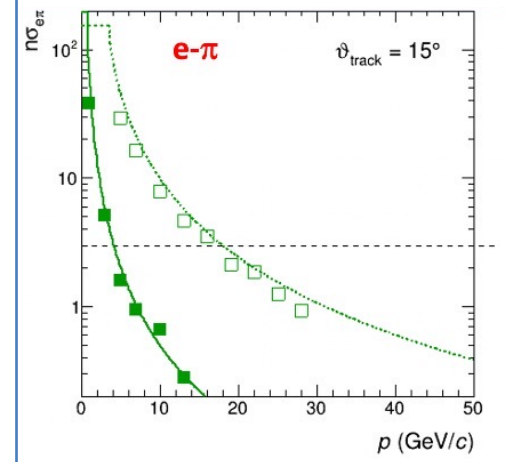

EIC_NET: Mechanics

Design thanks to A. Saputi, L. Barion

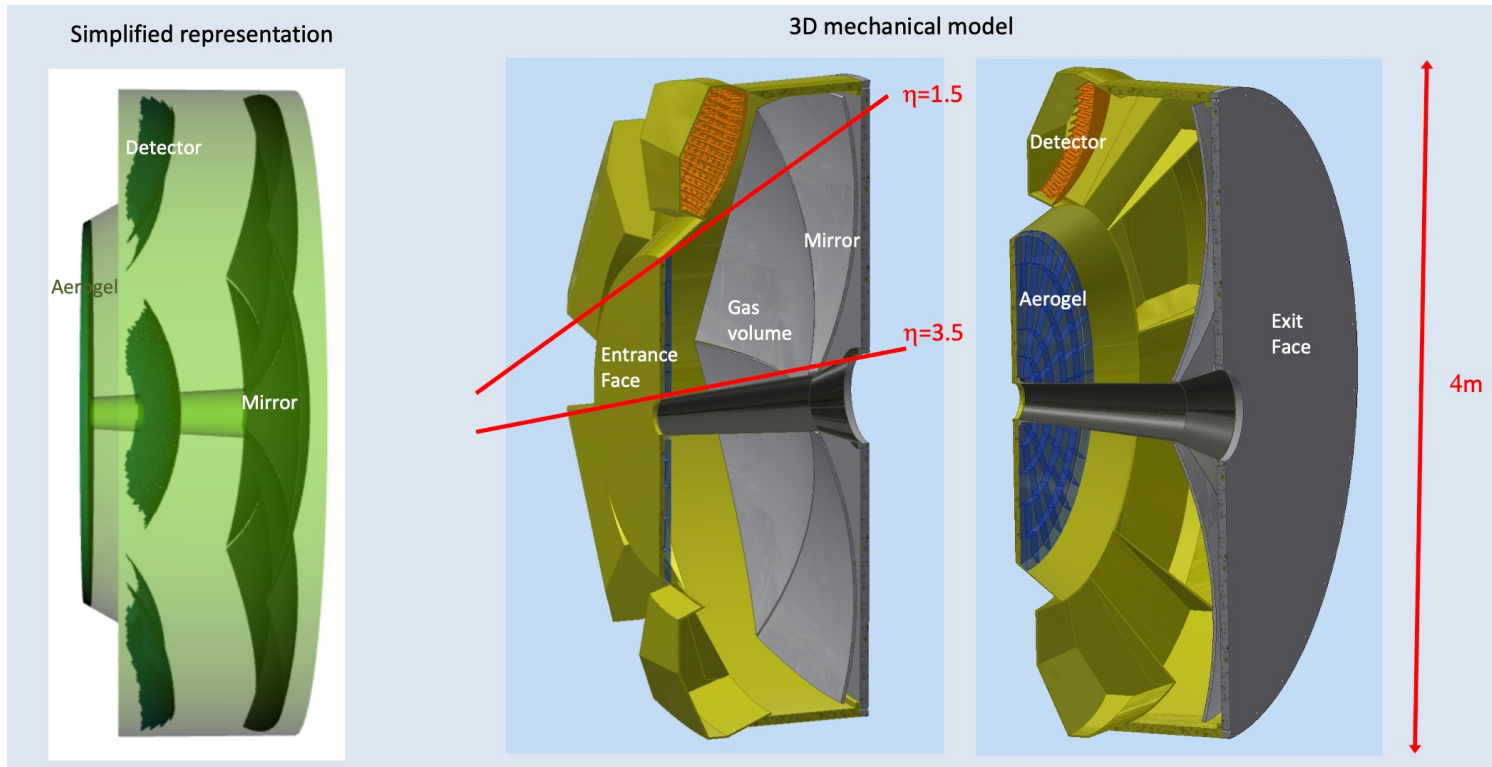

Windows: sandwich panel made of two ~ 1 mm carbon fiber reinforced epoxy skins separated by 30 mm PMI foam or Al honeycomb ($\sim 1\% X_0$)

Shells: 3 mm (inner tube) to 8 mm (outer tube) thick carbon fiber epoxy composite ($\sim 4\% X_0$)

Skins formed with two layers of balanced weave laminate with fibers at $0^\circ/90^\circ$ and $\pm 45^\circ$ for uniform stiffness

EIC_NET: SiPM

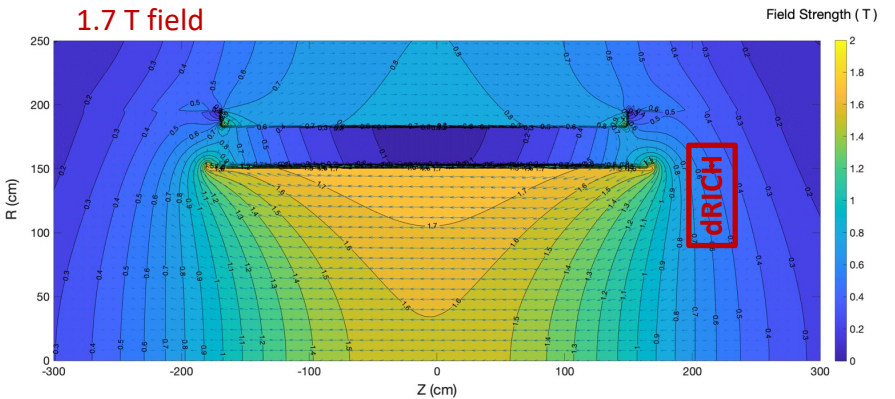
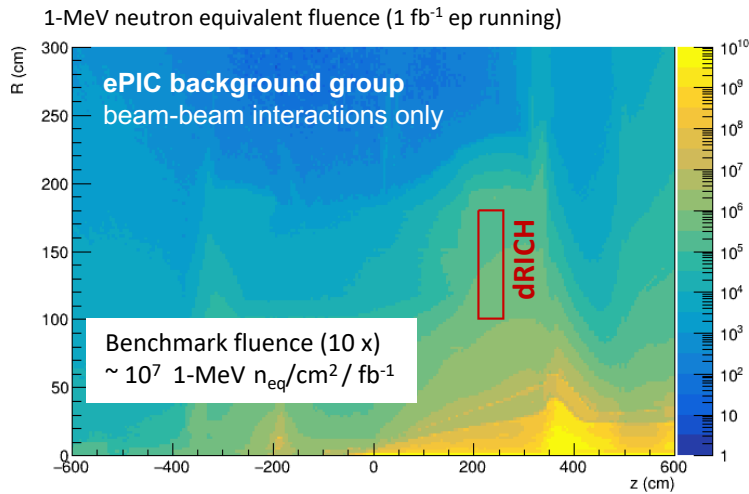

R. Preghenella, NIIMA 1046 (2023) 167661

Strong and not-uniform magnetic field

Moderate radiation levels (up to 10¹¹ n_{eq}/cm²)

Usage of SiPM with

- low temperature working point
- periodic annealing at high temperature (in-site by Joule effect)

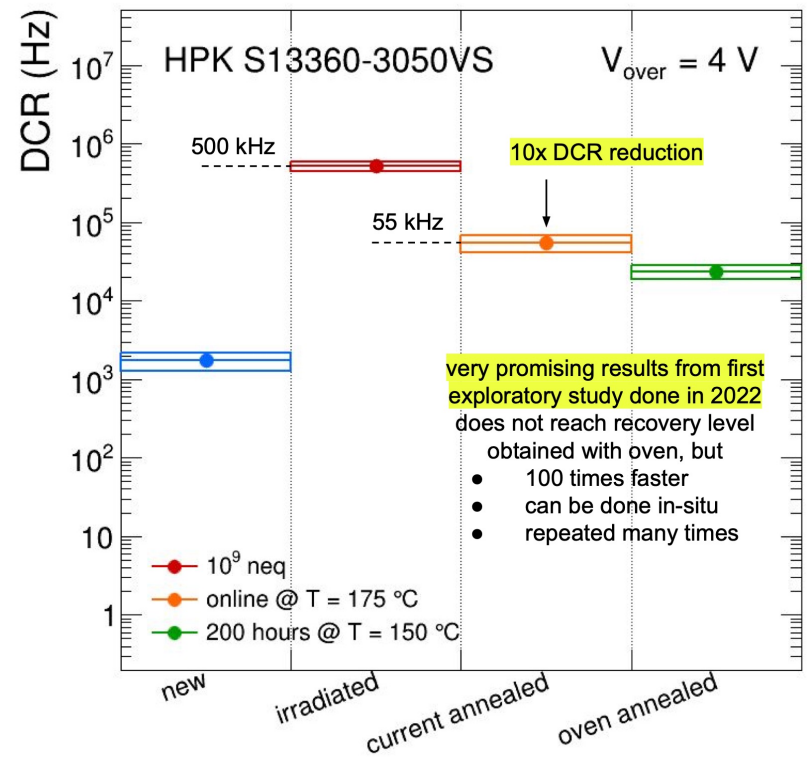

EIC_NET: Photo-Detector

Active area is shaped to resemble the focal surface and best exploits the focalization.
Electronics is minimized to fit the limited available space.

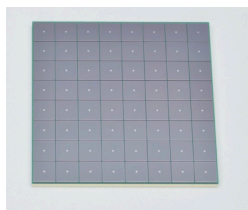
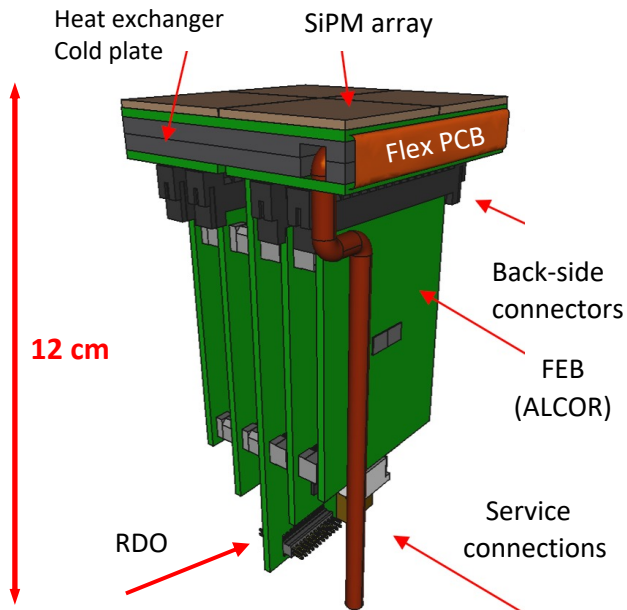

SiPM array



ALCOR chip

Photon Detector Unit (PDU):

Compact to minimize space

4x Hamamatsu S13361-3050HS SiPM arrays

4x Front-End Boards (FEB)

4x ALCOR chip (ToT discrimination)

1x Read-Out Board (RDO)

1x Cooling plate (< -30 C)

Detector box:

Shaped to fit the space

Quartz window

Cooling for sensors and electronics

Power distributing patch panel

Heat insulation

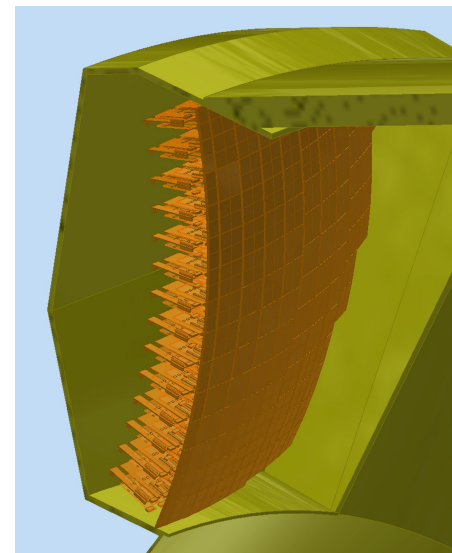
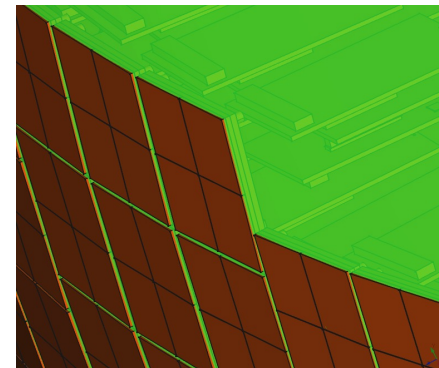

Design thanks to L. Barion, A. Saputi

EIC_NET: dRICH Prototype

Operative prototype commissioned. Double ring imaging achieved. Performance in line with expectations except for aerogel single-photon angular resolution (worse by a factor ~ 1.5)

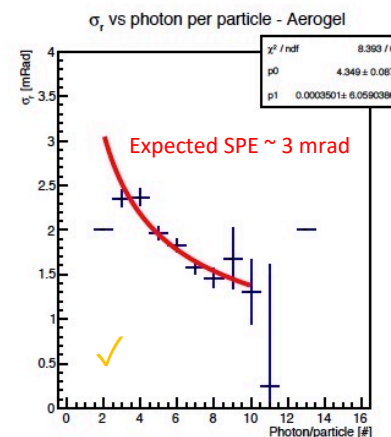
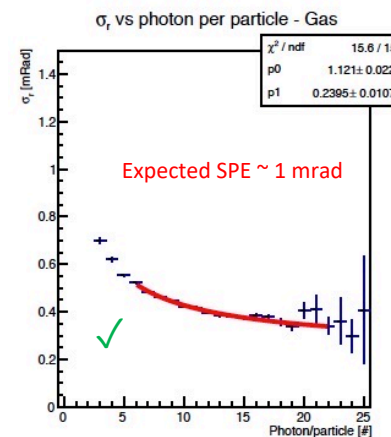
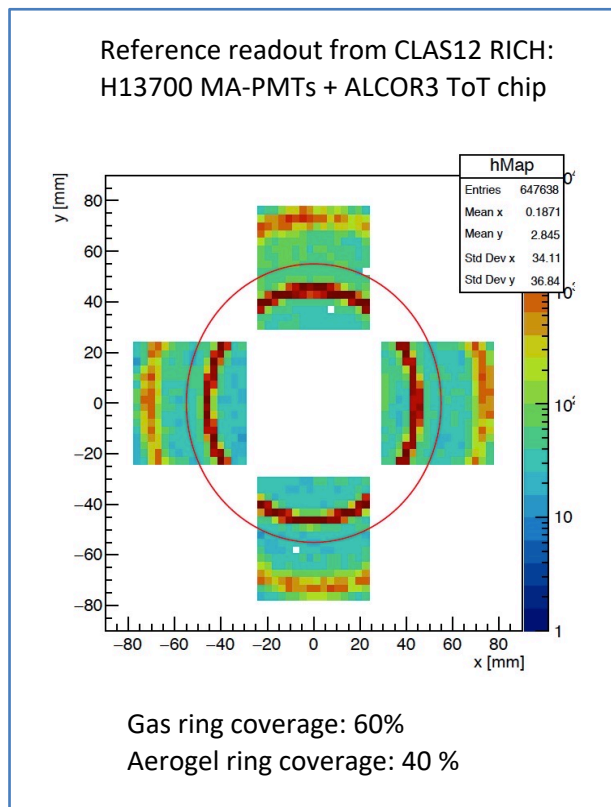
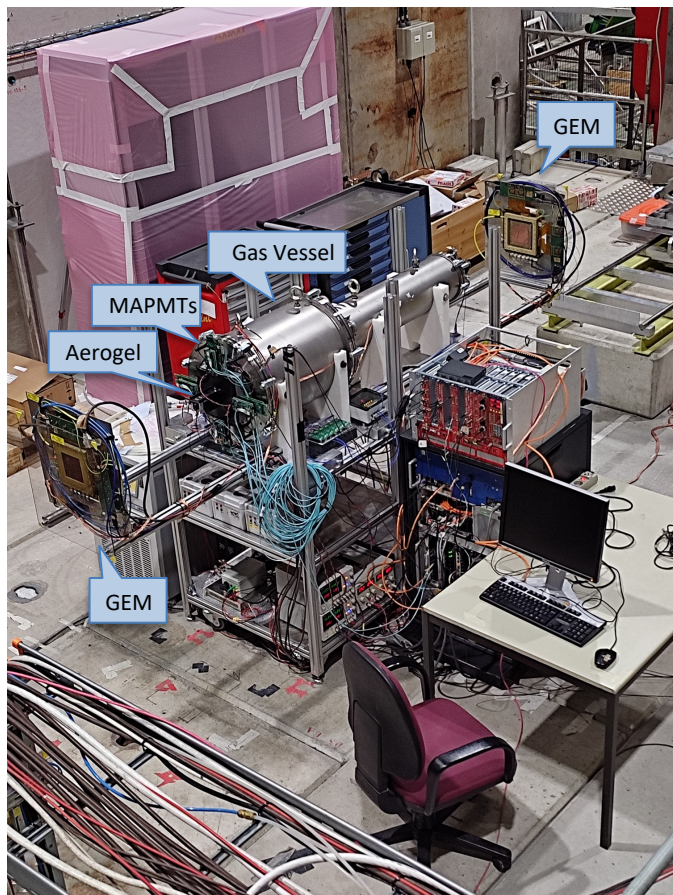

Optics at variance with respect EIC

Realization thanks to L. Barion, M. Cavallina, R. Malaguti

EIC_NET: dRICH Prototype

RICH 2022

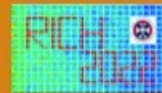

XI INTERNATIONAL WORKSHOP ON
RING IMAGING CHERENKOV DETECTORS

DEDICATED TO THE MEMORY OF JACQUES SÉGUINOT

EDINBURGH, UK

12 – 16 SEPTEMBER 2022



Co-winner of the early career poster prize:

Simone Vallarino
INFN Ferrara

**The dual Ring Imaging Cherenkov detector
for the Electron-Ion Collider**

Sponsored by



<https://indico.cern.ch/e/rich2022>



rich2022@ph.ed.ac.uk

SCAN ME



EIC_NET: dRICH Aerogel

Aerogel Factory (BELLE-II)

Initial evaluation & Reproducibility
on small samples in synergy with ALICE

Transmittance & Transflectance

Nominal 2021 and measured 2021

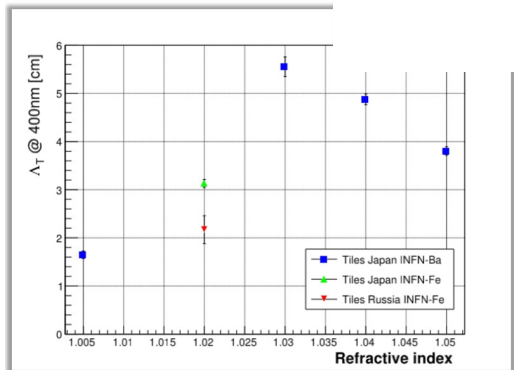
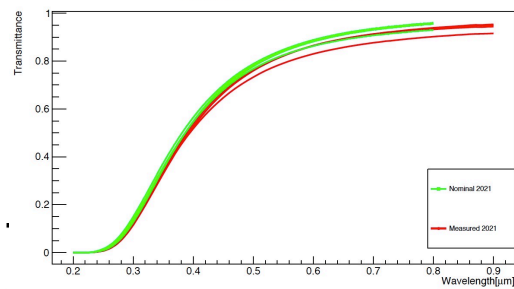

Density & refractive index

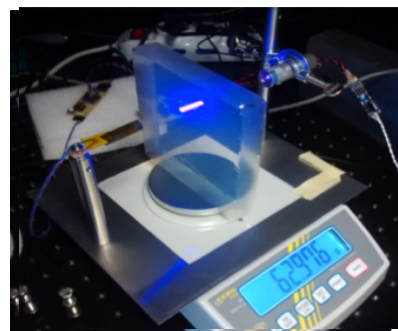
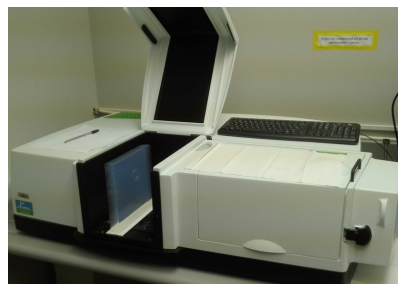

Laser spot bradening: Y profile

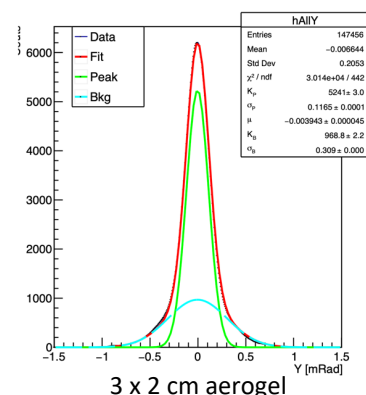
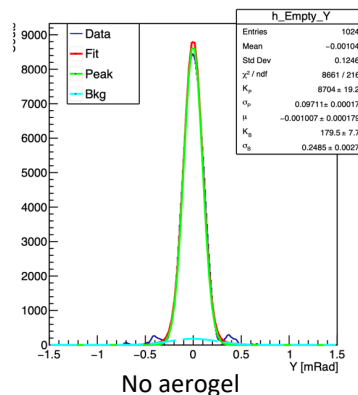

Touch Probe: planarity and thickness

10x10x2 cm³ tile
(from ALICE)

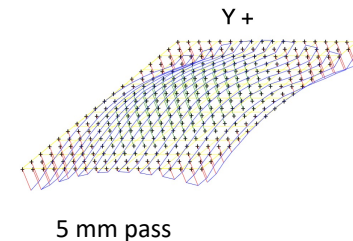
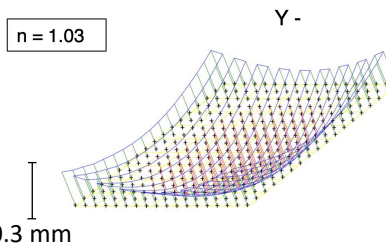

CLAS12 RICH quality assurance laboratory @ INFN-FE being refurbished

EIC_NET: dRICH Mirror

CMA Carbon fiber mirrors (HERMES, AMS, LHCb, CLAS12)

cost-effective light & stiff solution:

roughness driven by mandrel 1-2 nm rms

surface accuracy better than 0.2 mrad

radius reproducibility better than 1 %

Surface Quality

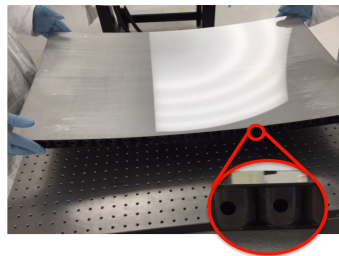
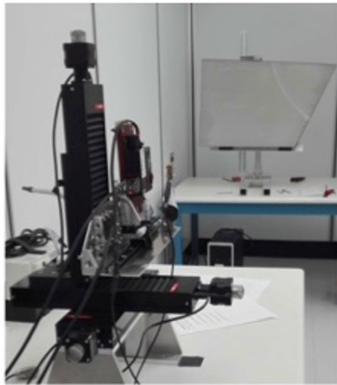

Shack-Hartmann sensor
Mirror aberrations

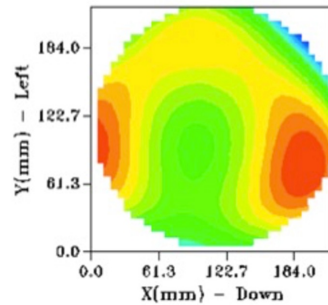

3.5 m

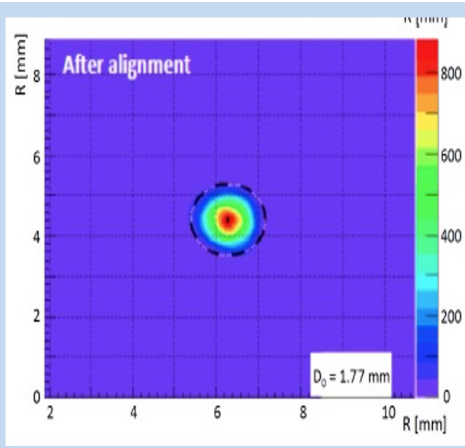
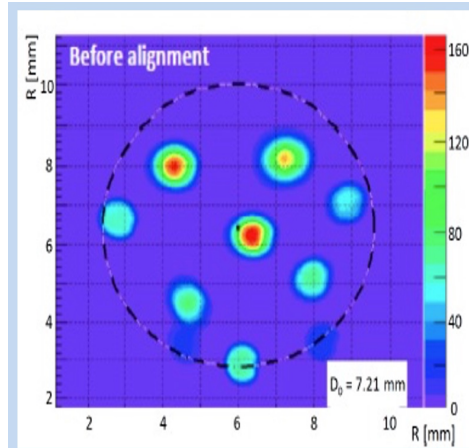

CLAS12 RICH quality assurance laboratory @ JLab being refurbished in collaboration with DUKE

EIC_NET: dRICH Prototype Highlight

Realization of a suitable detector plane for the dRICH prototype (23/10): Design ready, procurement aligned to 2023 test-beam campaign.

Hamamatsu S13361-3050

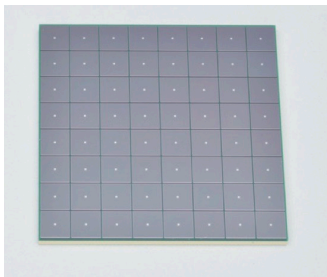

8x8 array
50 μm cell
Excellent fill factor
Best DCR

S14160 alternative

MPPC arrays selected with irradiation campaign

Front-end re-design completed

ALCOR v2 (better dynamic range and rate)

ToT architecture, streaming mode ready

- 50 ps time bin
- 500 kHz rate per channel
- cryogenic compatible

ALCOR chip

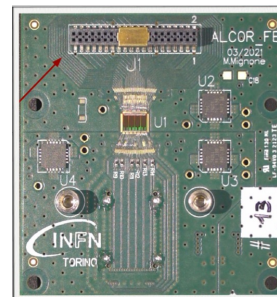

Multi-wafer run done

Version2:

32 channels
Extended dynamic range
Improved digital time



Integrated Cooling/ In-situ annealing

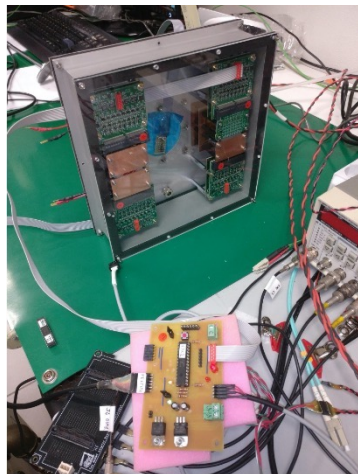

Cooling plate

Peltier cells

Annealing circuitry

New EIC-driven readout unit

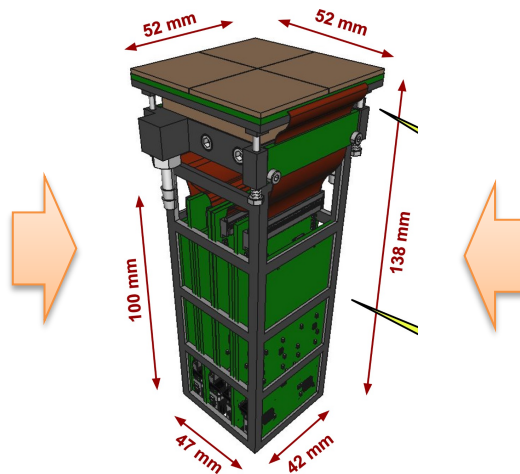

Streaming readout



2023:
1 RDO per chip

2024:
1 RDO per PDU

Development
Kit KC705

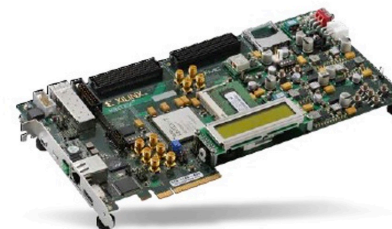

Realization thanks to L. Barion, M. Cavallina, R. Malaguti

EIC_NET: dRICH Prototype Milestones

2023: EIC-driven detector plane

- ✓ Initial characterization of realistic aerogel and mirror components (23/04);
- ✓ Projected performance of the baseline detector as integrated into EPIC (23/06);
- ✓ Assessment of the dRICH prototype performance with the EIC-driven detection plane (23/10).

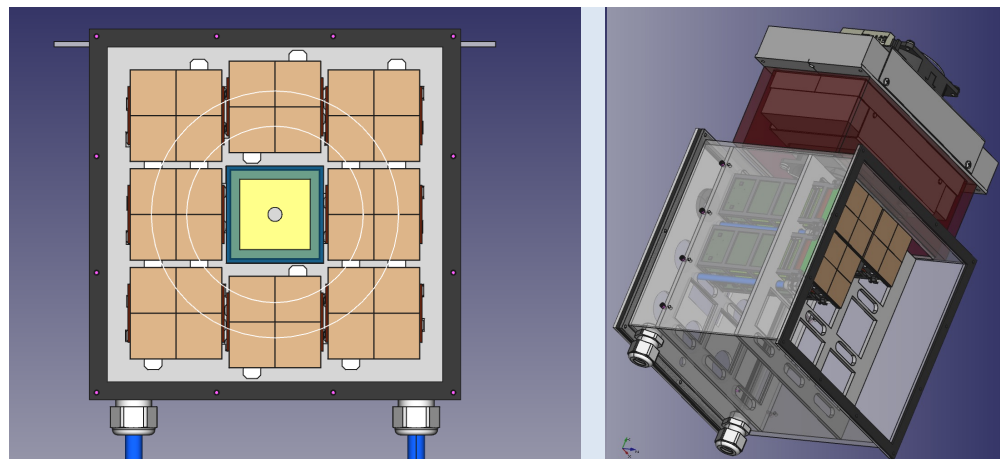

Test beam planned in August and October 2023

2024: Real-scale prototype for TDR (1 sector)

- Mechanical structure
- Realistic optics (off-axis)
- ALCOR64 FEB + RDO
- Aerogel and mirror demonstrator

New EIC-driven readout unit

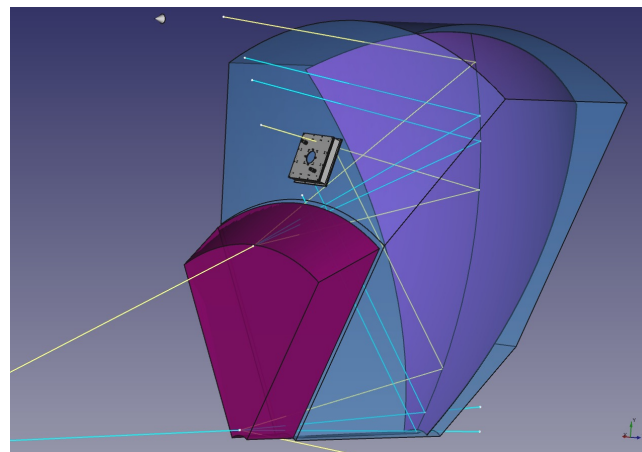
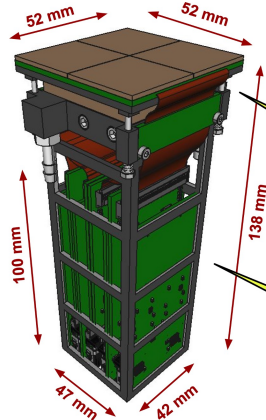

Realization thanks to L. Barion, M. Cavallina, R. Malaguti

EIC_NET: responsabilità

Responsabilità:

- M. C.: responsabile locale EIC_NET
- M. C.: responsabile dRICH
- A. S.: Contact for dRICH mechanics
- M. C.: co-coordinator eRD102
- M. C.: IAC POETIC (Physics Opportunities at EIC) Conference

Contributi principali:

- dRICH detector
 - dRICH mechanics
 - Prototyping
 - Optical component characterization
 - SiPM irradiation program
- Electronics
 - MAROC (reference) + ALCOR (INFN development)

Richieste ai Servizi

Servizio Meccanico

FE laboratory: supporto per misure e stazioni di test, preparazione test-beam

JLAB12

TTarget: supporto per test con doppio campo magnetico al LASA di Milano

High-Lumi: simulazioni stabilita' meccanica μ -rwell

Recoil: contributo meccanica tracciatore recoil

EIC_NET

dRICH: progettazione meccanica del rivelatore dRICH

dRICH: meccanica del prototipo dRICH

Servizio Elettronico

FE laboratory: supporto per misure e stazioni di test, preparazione test-beam

JLAB12

TTarget: piccoli contributi alle misure con magneti superconduttori

TTarget: contributo per recoil detector (μ -rwell e/o fibre scintillanti)

EIC_NET

dRICH: contributo piano di rivelazione curvo basato su SiPM + ALCOR

Manpower e richieste finanziarie per 2021

Anagrafica e afferenze (Ric. + Tecnol.)

Name	JEDI	JLab12	EIC_NET
N. Canale (dottorando)	100		
G. Ciullo (staff)	70	20	
M. Contalbrigo (staff)		50	50
S. Dymov (post-doc)	100		
L. Del Bianco (staff)		100	
A. Kononov (dottorando)	100		
P. Lenisa (staff)	75	20	
A. Maragno (dottoranda)	100		
L. Pappalardo (RTD-B)		30	
A. Pesce (post-doc)	100		
A. Selev (assegnista)	100		
R. Shankar (dottorando)	100		
F. Spizzo (staff)		80	20
S. Vallarino (dottorando)		100	
V. Carassiti	10		
A. Cotta Ramusino (staff)	10		
TOTALE/100	8.6	4.0	0.7

Servizio meccanico ed elettronico

Name	JEDI	JLab12	EIC_NET
L. Barion		25	75
M. Cavallina	10	10	
M. Gambetti	10		
R. Malaguti		20	
M. Melchiorri			10
S. Squerzanti		20	
TOTALE/100	0.2	0.5	0.1

Richieste finanziarie (k€)

Name	JEDI	JLab12	EIC_NET	Dot.3
Missioni	57	45	15	8
Trasp.		5		
Inv.	9			15
Consumi	34.5	15	20	6
Apparati		20		
Altro				3
TOTALE	100.5	85	35	32