

dRICH Project Overview

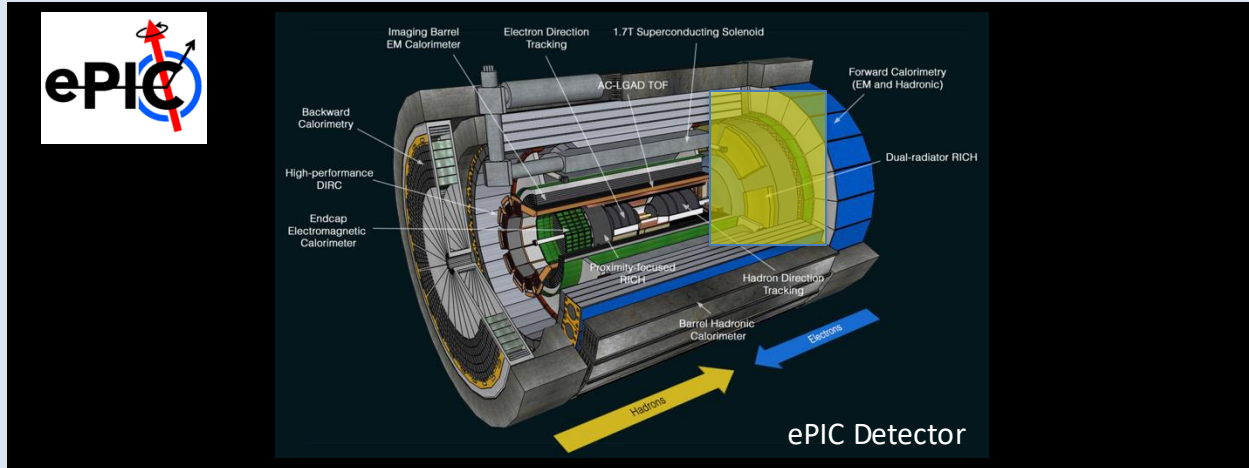

M. Contalbrigo – INFN Ferrara - DSCL

Meeting with INFN referees, Torino, July 26th, 2025

Dual-radiator Ring-imaging Cherenkov Detector (dRICH)

Essential to access flavor information

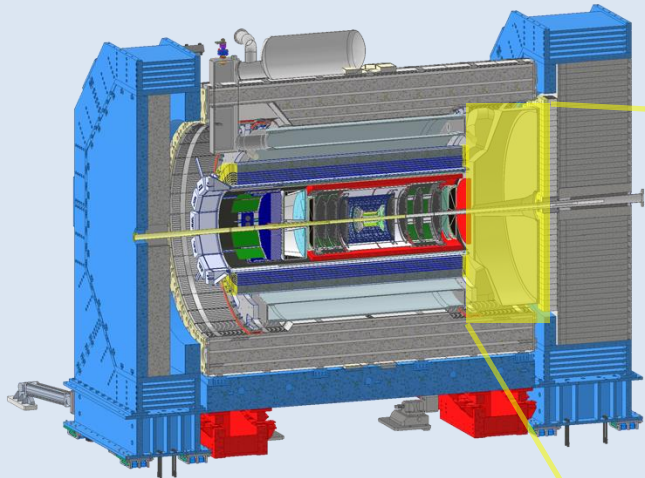

Goals:

Hadron 3σ -separation between 3 - 50 GeV/c
 Complement electron ID below 15 GeV/c
 Cover forward pseudorapidity 1.5 (barrel) - 3.5 (b. pipe)

dRICH Features:

Extended 3-50 GeV/c momentum range --> **Dual radiator**
 Single-photon detection in high Bfield --> **SiPM**
 Limited space --> **Compact optics with curved detector**

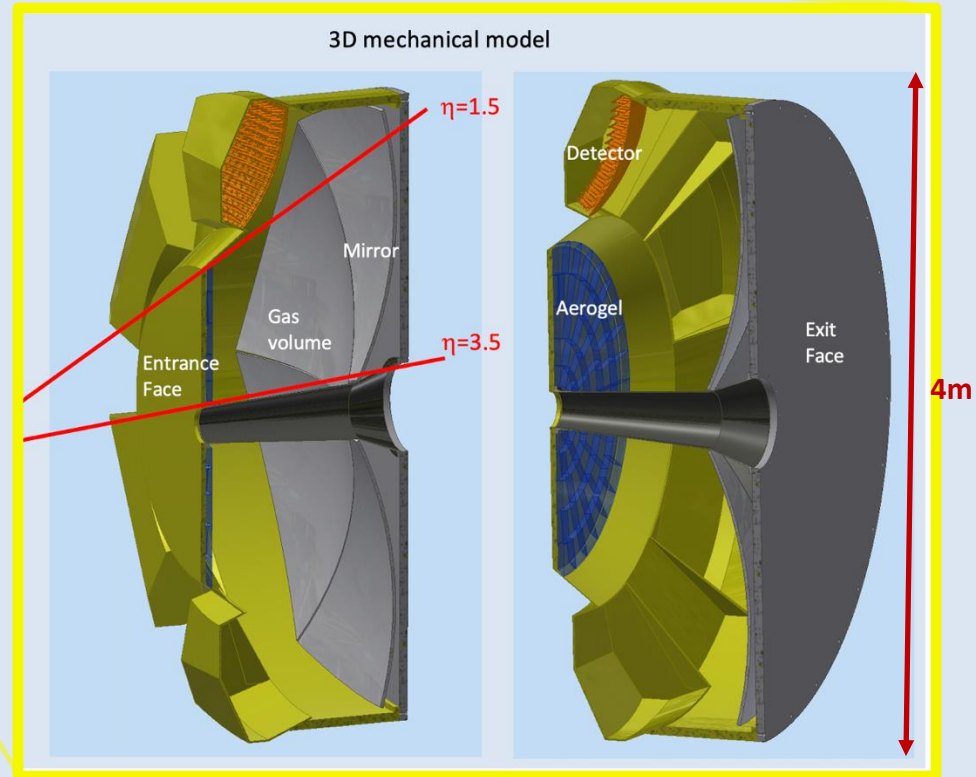

April 1-2 Incremental Preliminary Design and Safety Review of pFRICH, dRICH and hpDIRC
 “60% Preliminary Design Review”

PASSED

April 16 EIC Project Detector R&D Day

June 11-13 10th EIC Detector Advisory Committee Meeting

ON TRACK

•(dRICH) The chromatic error is dominating the overall performance of the aerogel. It is recommended to study the optimization between (a) loss of photon yield and (b) reduction in chromatic error, using a possible optical filter installed after the aerogel tiles.

Simulations

•(dRICH/DAQ) High level filtering of interactions through the GTU is being built into the DAQ design, with the specific example of the dRICH filtering provided. As this is developed the ePIC collaboration should work to understand the dependence between detectors this may introduce and prioritize the external inputs for this online filtering for different detectors.

DAQ

•(dRICH) In order to optimise the ALCOR time gate, a simulated distribution of the time-of-arrival of the photon signal (and background) on the photon detector plane would be required, together with an evaluation of the main front-end electronics contributions (if any) before the application of the time gate.

Simulations















•(dRICH) Preliminary results from studies of the SiPM array optical window after annealing were shown. A more detailed evaluation of the effect of high-temperature annealing on the shape integrity and optical properties of the resin layer is advised.

Annealing

Global services (cables, cooling, etc.) through the endcaps have been identified, including their impact on the hpDIRC and dRICH positioning. These should continue to be monitored to allow reasonable overhead for packing and inevitable increases as additional services are identified.

Cooling

Design Status

	Technical requirements		Validated technical solutions	2026
Aerogel:	Momentum reach above 15 GeV/c to overlap with gas More than 10 detected photons from 4 cm thickness Single photon resolution approaching 2 mrad		n = 1.026 dn/dλ = 6 · 10 ⁻⁶ nm ⁻¹ scattering length > 50 mm	 Dimensions
Gas:	Momentum reach above 50 GeV/c at pseudorapidity > 2.5 More than 20 detected photons from 1 m depth Single photon resolution approaching 1 mrad		C ₂ F ₆ with n = 1.00086 dn/dλ = 0.2 · 10 ⁻⁶ nm ⁻¹ absorption length > 100 m	 Purging Monitoring
Mirror:	Focalization of Cherenkov light onto the detector surface Preservation of the Cherenkov information Material budget limited to O(2 %) of radiation length		Carbon fiber material Roughness of few nm Angular precision < 0.3 mrad	 Coating
Sensors:	Single photon detection capability in highly non-uniform magnetic field Excellent PDE in the visible range to cope with aerogel Marginal contribution to the angular resolution Preserve prompt Cherenkov information Tolerance to few 10 ¹⁰ 1-MeV neutron equivalent fluence		SiPM Spatial resolution of 3 x 3 mm ² Time resolution O(100 ps) Operation at < -30 degrees Annealing curing cycles	 Layout Annealing Carrier
Readout:	Below 1 p.e. signal threshold capability Preserve sensor time resolution to cope with dark counts and accidentals More than 300 kHz/ch rate capability		ALCOR ALCOR chip (ToT architecture) Time resolution < 200 ps Rate > 300 kHz/ch	 ALCOR 64ch BGA package FEB
DAQ:	1.3 Tbps maximum data throughput Streaming readout Suppression of no-interaction frames		AMD Artix FELIX VTRX+ transceiver Polarfire scrubber GTU trigger	 RDO Data filter dRICH tagger
Mechanics:	Acceptance maximized in 1.5 – 3.5 pseudorapidity range Material budget minimized in acceptance Compatibility with barrel maintenance at IP6		Composite materials Single open volume Detector in the barrel shadow	 Real-scale prot. Detector box Cooling

Construction Plan

A construction and QA plan is outlined accounting for lead, assembling and commissioning time

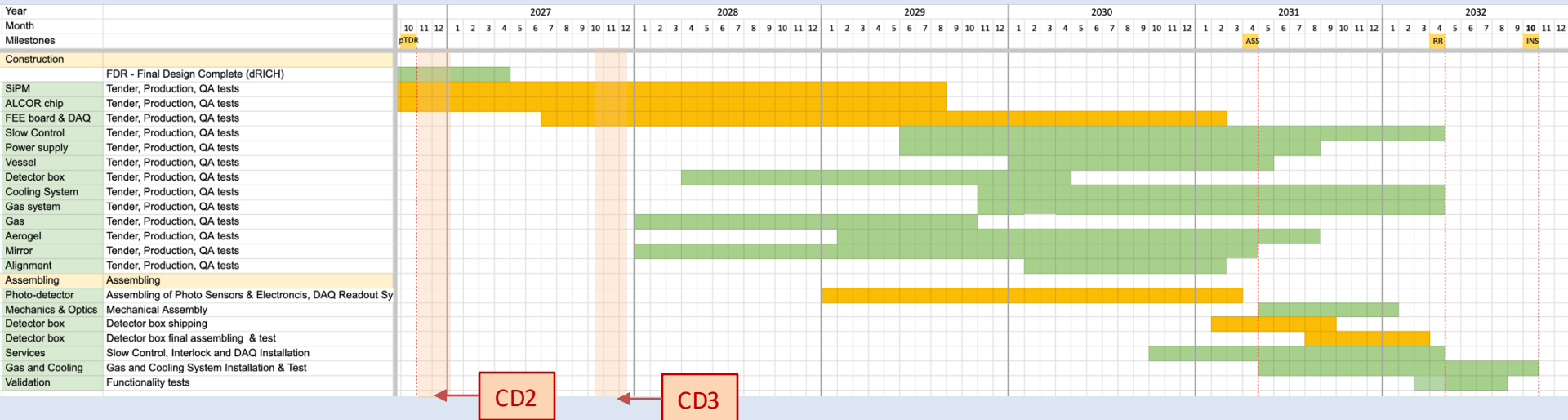

- CD-2:** Validate ALCOR-64 & RDO design
 Validate real-scale prototype mechanics
 Study detector box engineering
 Details the aerogel tile dimensions
 Determine a baseline for online data filtering
 Work out a baseline cooling & gas sytem

- CD-3:** Optimize component performance
 Complete component integration
 Finalize cooling & gas system
 Detail detector integration and maintenance

Stage 1: Procurement for the PDU components (asics, SiPM, carrier, FEB, RDO...)
 Anticipate mirror and gas procurement to reduce risk

Stage 2 : Central 2-3 year for the detector box assembling before delivery to BNL
 Aerogel production after engineering optimization
 Gas system realization after BNL authority approval

Stage 3: Mechanical structures and assembling
 Completino of services
 6 months of contingency and functionality tests

INFN Funding Profile

- Constraints:
- Installation in 2032
 - Detector boxes ready to be moved to BNL in 2031
 - SiPM production done in a row (2 yr)
- Assumptions
- possibility to spread the major procurements in batches/years
- Potential risk:
- late investment on aerogel & mechanics

Peak investment being mitigated with respect 2024 anticipation

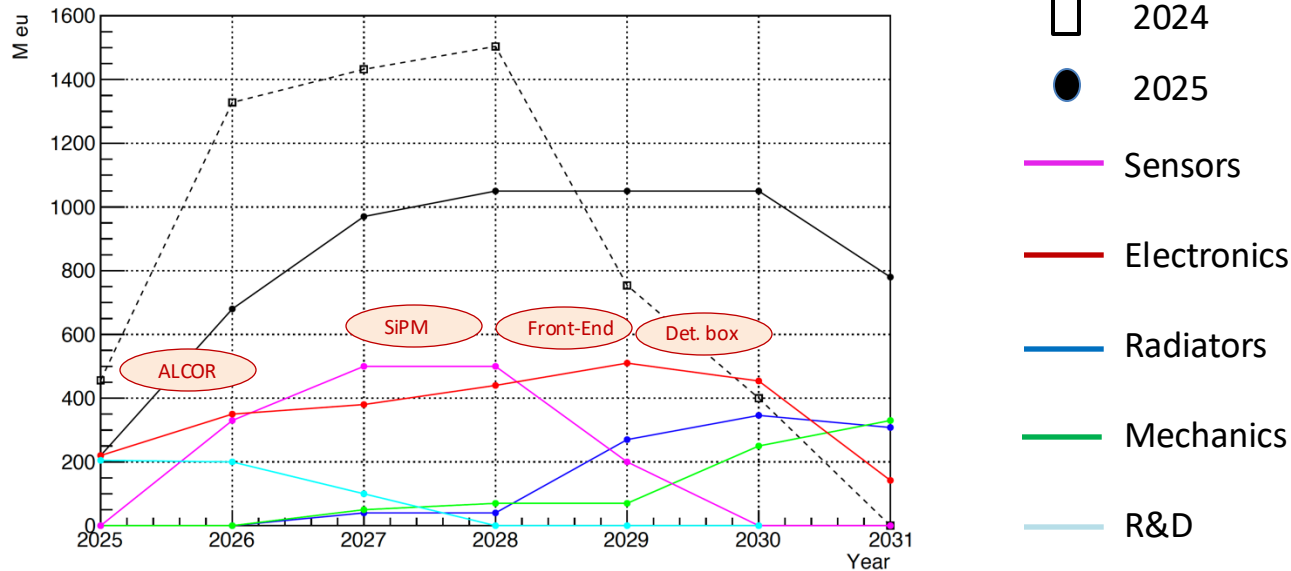

QA is organized to allow essential acceptance tests on 100% of components plus in-depth sample characterization

QA stations organized in order to

Be close to the assembling site

Ensure adequate personnel training

Provide redundancy & investment synergy

Support specific in-deep characterization studies

Aerogel: Integrity, defects, transmittance, refractive index, dimensions, planarity

Mirror: Dimensions, shape accuracy, radius, reflectivity

Sensors: Electrical connections, quench resistor, I-V characteristics, DCR, relative PDE

Readout: Electrical connections, bias levels, threshold and gain scans, time jitter, DAQ rate

Gas: Refractive index, transparency, sound speed, leakage rate

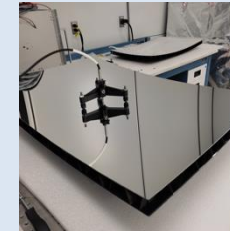
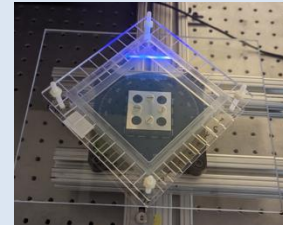
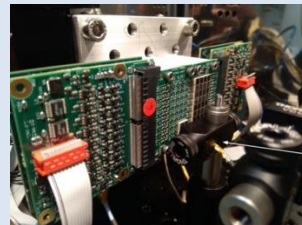
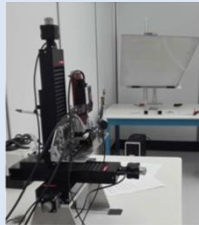

Component	QA station 1	QA station 2	QA detail and backup	QA Acceptance	In-depth
Aerogel	Temple U.	BNL	INFN-BA	100 %	5%
Gas	BNL		INFN-TS	2 %	2%
Mirror	JLab	Duke U.		100 %	10%
Sensor (SiPM)	INFN CS-SA-CT	INFN-TS	INFN-BO	100 %	1%
Readout	INFN-BO	INFN-FE	INFN-TO	100 %	1%

A detailed mechanical model of the single-vessel detector is outlined with composite materials

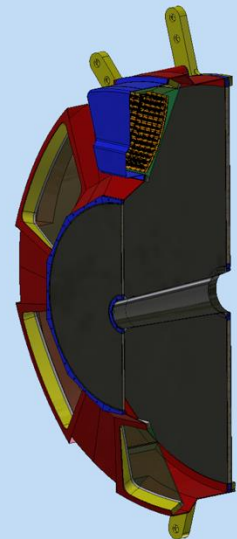

Composite materials

Total weight: ~ 2 ton

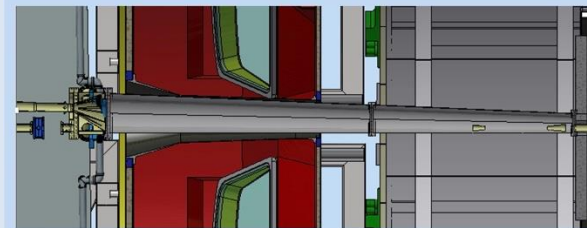
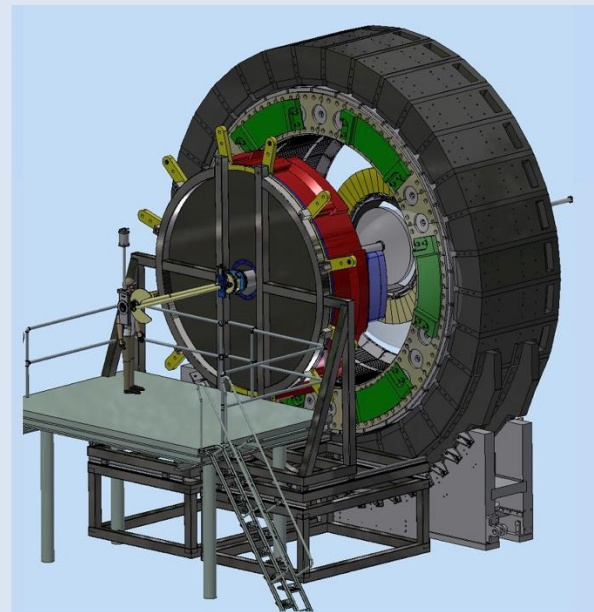
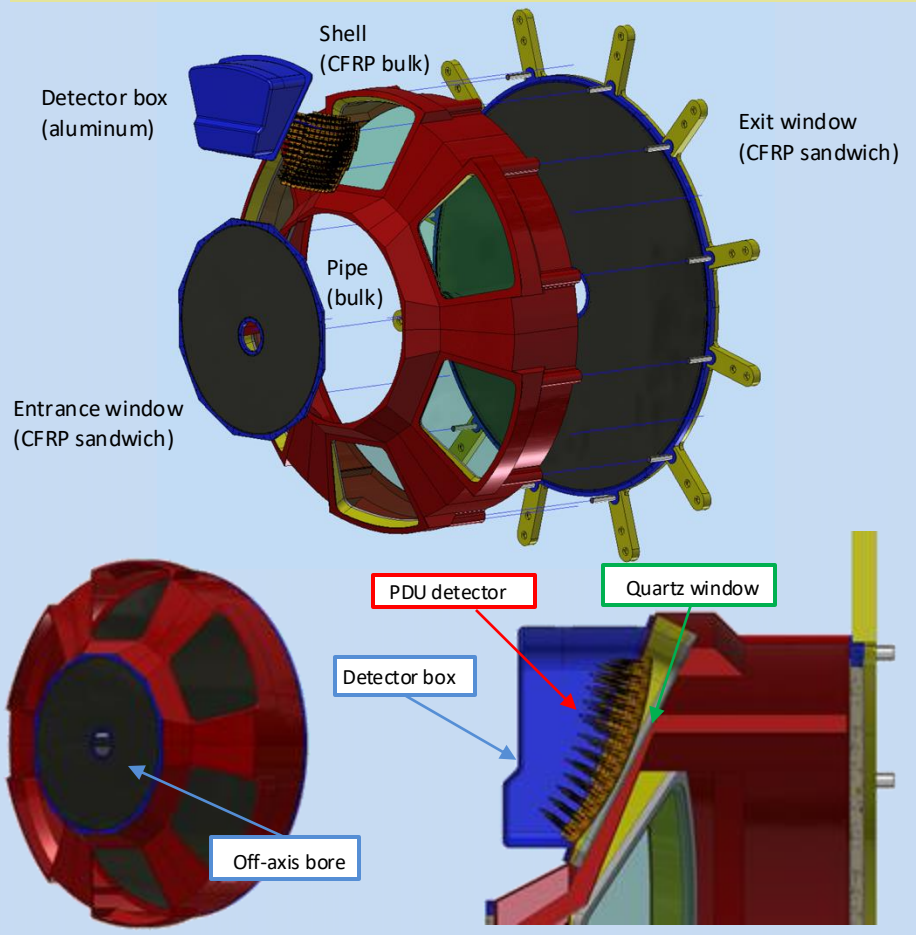

Optical quality of mid-size samples being validated with lab characterization

Optics: Good reproducibility of refractive index
Transmission length > 50 mm (best worldwide standard)

Type	15 x 15 cm ² , 3-cm thick		18 x 18 cm ² , 2-cm thick	
Serial number	AG20001	AG20002	AG19701	AG19702
Refractive index (at 405 nm)	1.0264	1.0263	1.0272	1.0272
Transmission length (at 400 nm) [mm]	53.9	58.1	52.8	52.9
Transmittance (at 400 nm) [%]	56.8	59.1	67.6	67.8
Lateral block size [mm]	146.5	146.7	176.8	177.1
Thickness [mm]	30.5	30.6	20.7	20.6
Weight [g]	62.94	63.82	62.42	62.63
Density [g/cm ³]	0.0962	0.0970	0.0965	0.0971
File name of transmittance data [.txt]	Same as ser			

Type	18 x 18 cm ² , 2-cm thick, INFN shape	
Serial number	AG19802W	AG19803W
Refractive index (at 405 nm)	1.0273	1.0274
Transmission length (at 400 nm) [mm]	53.0	50.8
Transmittance (at 400 nm) [%]	68.4	67.8
Block size/shape	As designed	As designed
Thickness [mm]	20.1	19.8
Weight [g]	44.10	Not determined
File name of transmittance data [.txt]	Same as serial numbers	

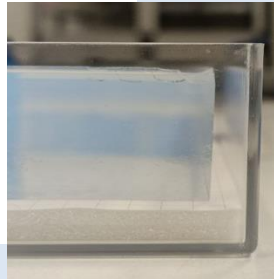

Engineering of the aerogel wall expected by 2026

Goal: > 20 x 20 cm² to minimize dead area

To be checked: Quality vs production yield

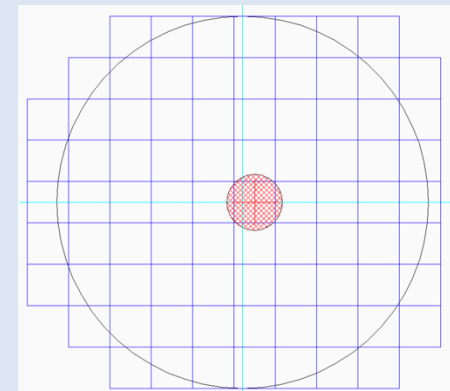
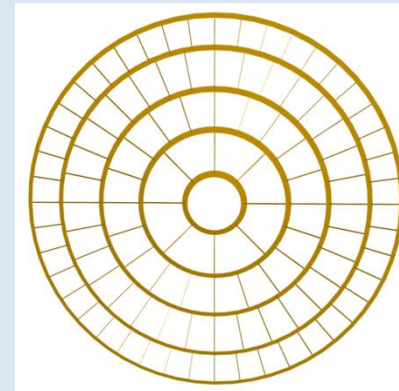
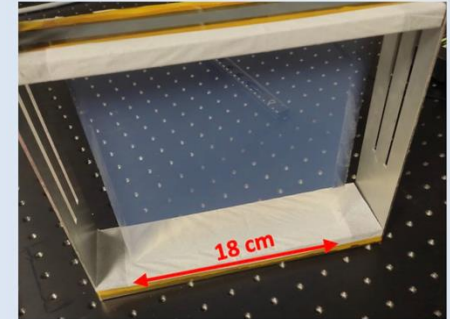
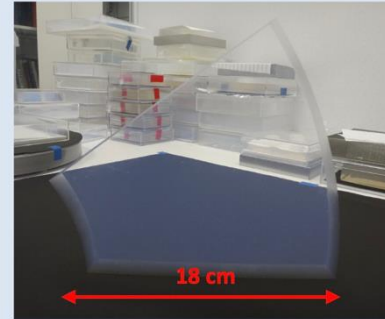

Mechanics: Meniscus & shrinkage requires edge cutting
Water-jet cut ensures precise shaping

Checking surface flatness
Moving to 20 x 20 cm²

Mirror

CFRP substrate mid-size (~50 cm side) demonstrator validated with lab tests before coating

Optics: Good surface precision
Acceptable radius of curvature
Moving to coating

Mechanics: Holder
Alignment

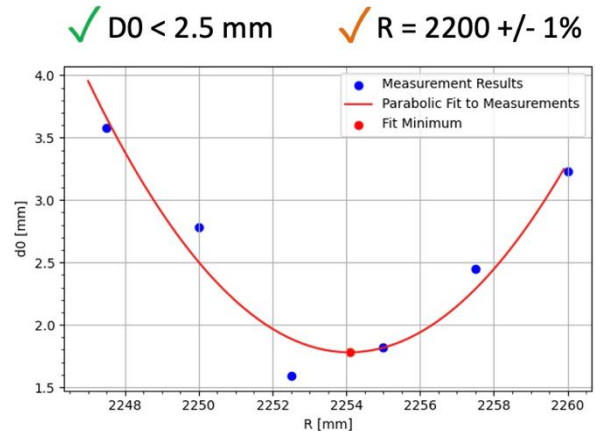
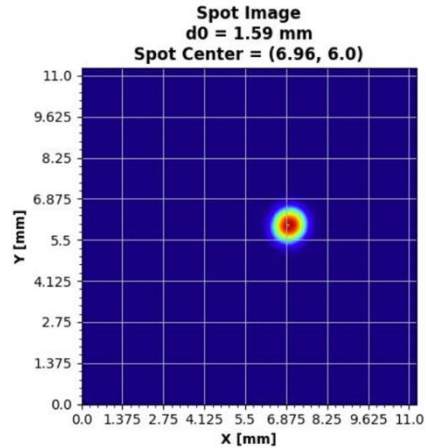
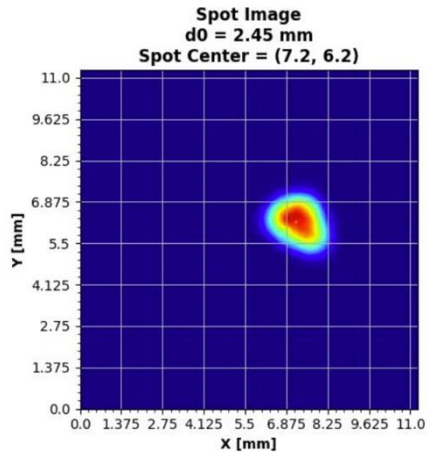
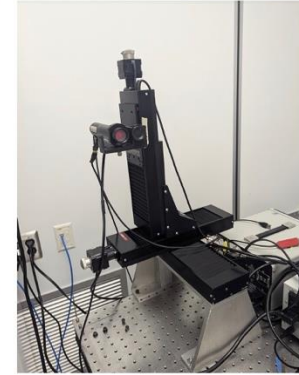
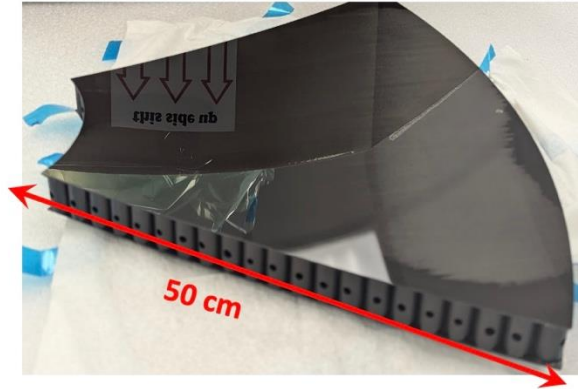

Engineering of all the mechanical details pursued with the real-scale prototype being realized in 2025

Aerogel demonstrator

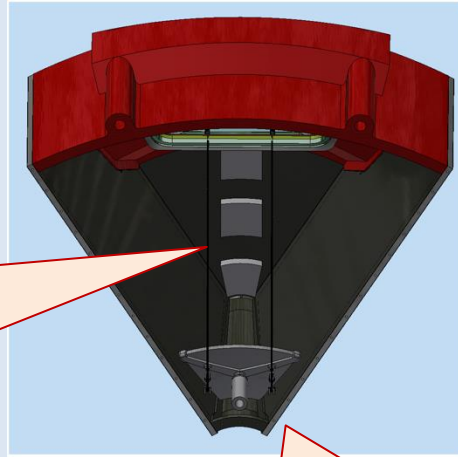
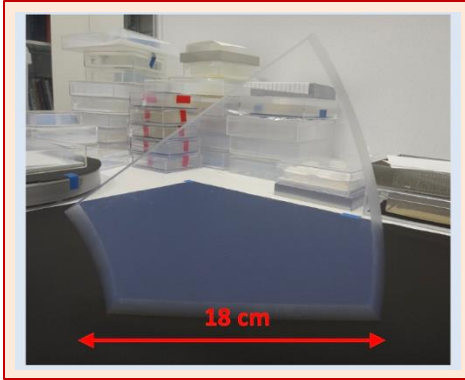

Under Construction

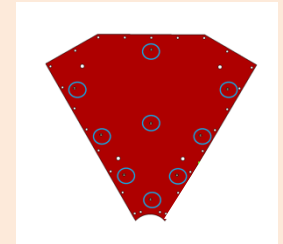
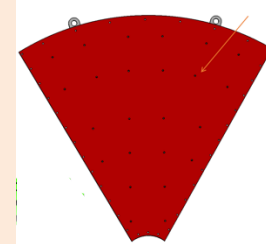
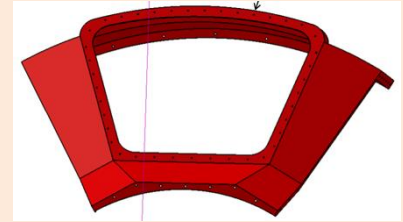

Mirror mounting and holder

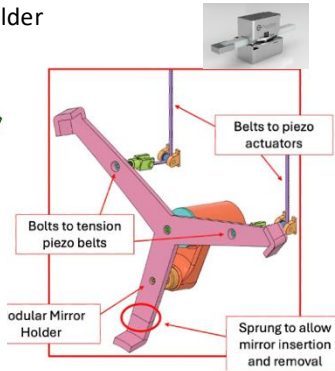
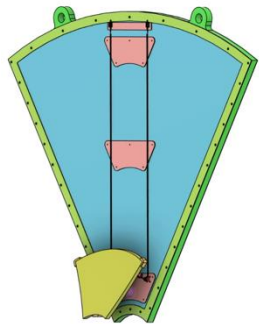

JLab

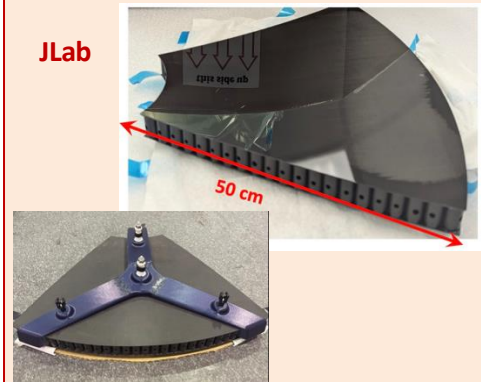

CFRP layer samples

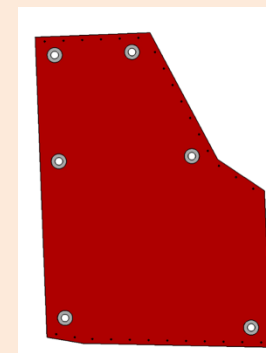

Lab tests:

- Mechanical stability
- Gas & light thightness
- Temperature gradients
- Assembling scheme
- Inner components supports
- Optical septa....

2025 beam-test goal:

Commissioning at SPS H8 in November

- Real scale 1-sector prototype with demo components
- ALCOR readout with RDO

2026 beam-test goal:

Performance validation with beam

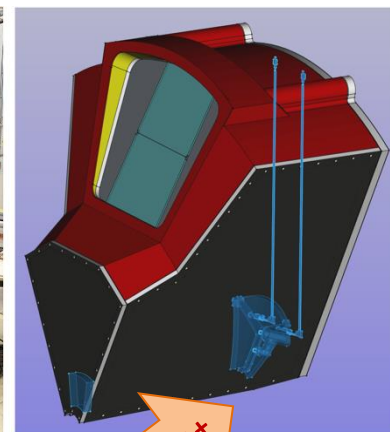
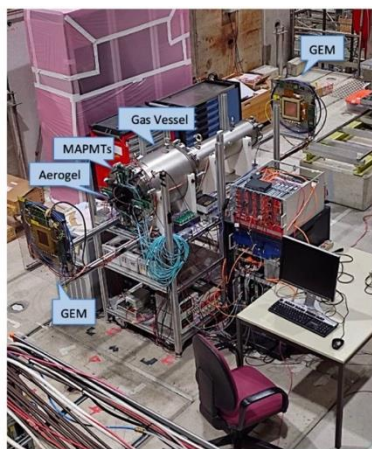

2025++

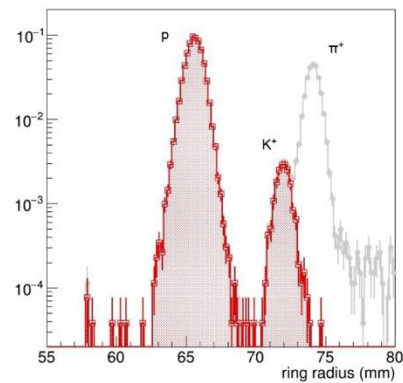
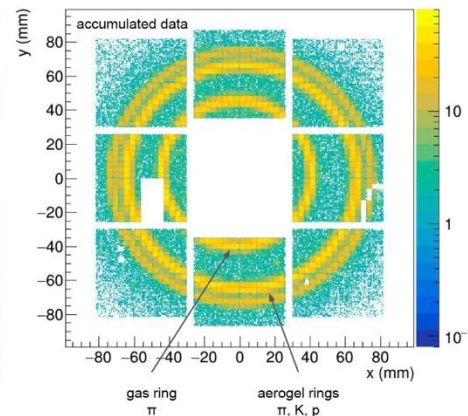
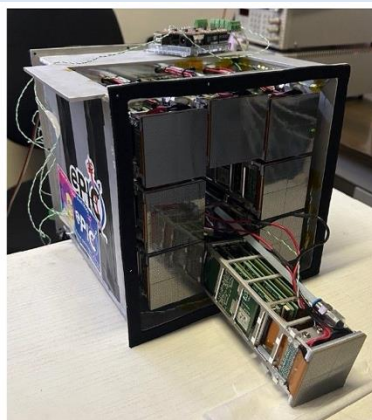

Engineering of detector box planned in 2026

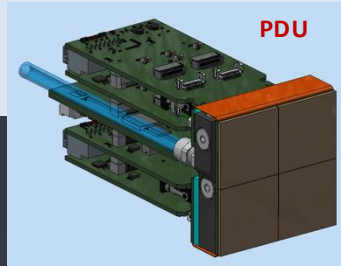

Support structure & services

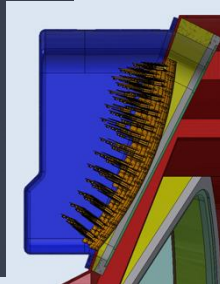
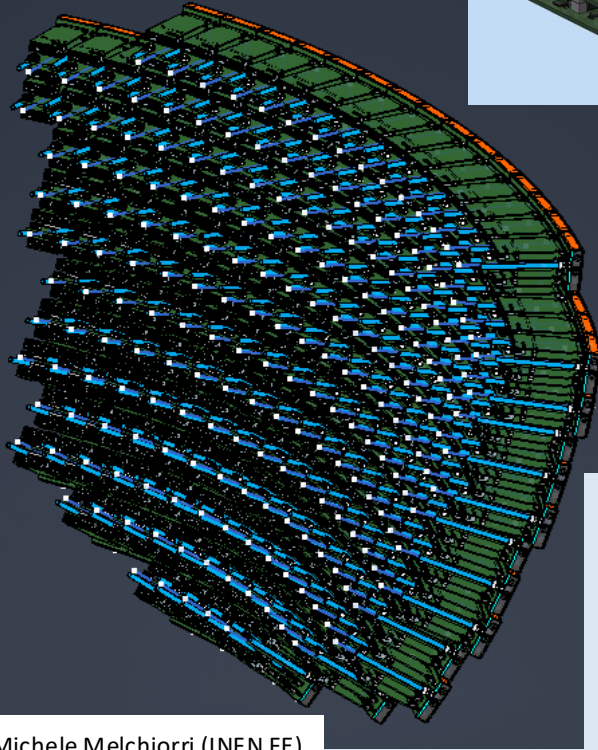

Michele Melchiorri (INFN FE)

Power & Master Panel

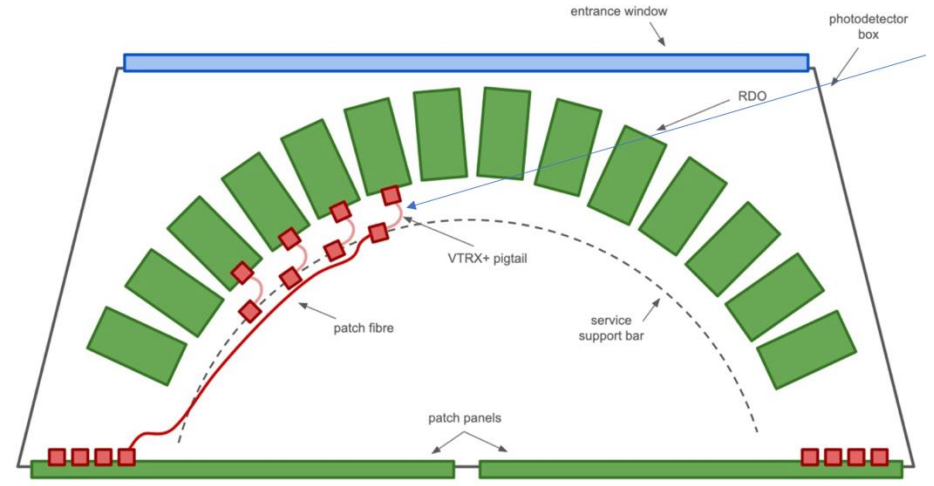

Cooling

Preliminary CFD (Computational Fluid Dynamics) Simulation

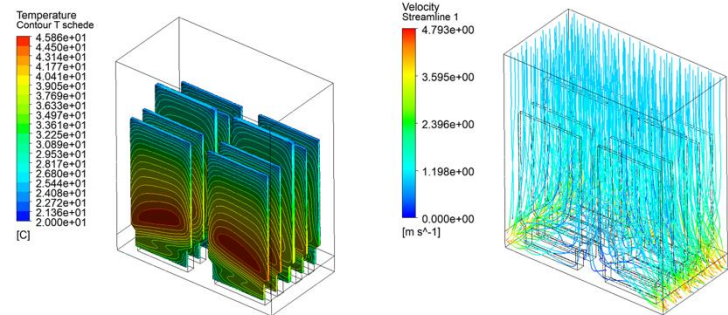

Marco Nenni, Carlo Mingioni (INFN TO)

Richieste 2026

Sezione INFN	Attività'	Capitolo	Cifra (keuro)	Motivazione
BA	Aerogel	Cons.	30	Engineering studies on large samples 20x20 cm ²
BA	Aerogel	Cons.	4	Rafraction index measurement
LNS	Real-scale prot.	Cons.	3	Metabolismo test meccanici su materiali compositi per prototipi
FE	Real-scale prot.	Cons.	5	Supporti componenti prototipo
FE	Real-scale prot.	Cons.	8	Piattaforma per movimentazione controllata prototipo scala reale
FE	Real-scale prot.	Inv.	3	Motoriduttori per movimentazione prototipo + meccanismi
FE	Real-scale prot.	Cons.	2	Telescopio cosmici per prototipo scala reale
FE	Real-scale prot.	Inv.	2	Pompa a membrane per ricircolo veloce gas
FE	Real-scale prot.	Cons.	6	Acquisto gas C ₂ F ₆ e Argon per gestione prototipi
FE	Real-scale prot.	Tras.	4	Trasporto prototipi
FE	Detector box	Cons.	8	Prototipo detector box
FE	Detector box	Cons.	5	Quarzi per prototipi
FE	Detector box	Cons.	9	Produzione schede elettronica per prototipo master panel

Preliminary commitments for the construction phase are defined

Institution	Nation	Activity
INFN-FE	Italy	Mechanics, detector box and control panels
INFN-BO	Italy	Photosensors, photodetection unit PDU and readout board RDO
INFN-TO	Italy	ALCOR and front-end board FEB
INFN-BA	Italy	Aerogel radiator
INFN-CS-SA-CT	Italy	SiPM quality assurance
INFN-GE	Italy	dRICH tagger
INFN-LNS	Italy	Mechanical design
INFN-RM1-RM-TV	Italy	Online data reduction
INFN-TS	Italy	Radiator gas, gas system and software, SiPM quality assurance
Duke-U.	USA	Mirror
JLab	USA	Mechanical design and mirror characterization
BNL	USA	Mechanical design, integration, infrastructure
Temple U.	USA	Aerogel quality assurance
M.S. Ramaiah U.	India	Simulations and performance study
NISER	India	Performance study
Central U. of Haryana	India	Performance study
Central U. of Karnataka	India	Performance study