



**A. Sytov^{1,2}, L. Bandiera¹, K. Cho², G. A. P. Cirrone³, H. Ehrlichmann⁴, V. Guidi^{1,5},
V. Haurylavets, G. Kube⁴, A. Mazzolari¹, M. Romagnoni¹, M. Soldani^{1,3},
M. Stanitzki⁴, M. Tamisari⁵, G. V. Tikhomirov, K. Wittenburg⁴**

¹Istituto Nazionale di Fisica Nucleare Sezione di Ferrara, Ferrara. Italy

²Korea Institute of Science and Technology Information (KISTI), Daejeon, Korea

³Istituto Nazionale di Fisica Nucleare Laboratori Nazionali del Sud, Catania, Italy

⁴Deutsches Elektronen-Synchrotron DESY, Hamburg, Germany

⁵Università degli Studi di Ferrara, Ferrara, Italy

**FUTURE DESY II BOOSTER SYNCHROTRON
PROOF-OF-PRINCIPLE EXPERIMENT FOR
A CRYSTAL-BASED EXTRACTION OF ELECTRONS**

**The 24th International Conference on Accelerators and Beam Utilizations
ICABU2022**

Gyeongju, 2022/11/10

The world of the channeling effect

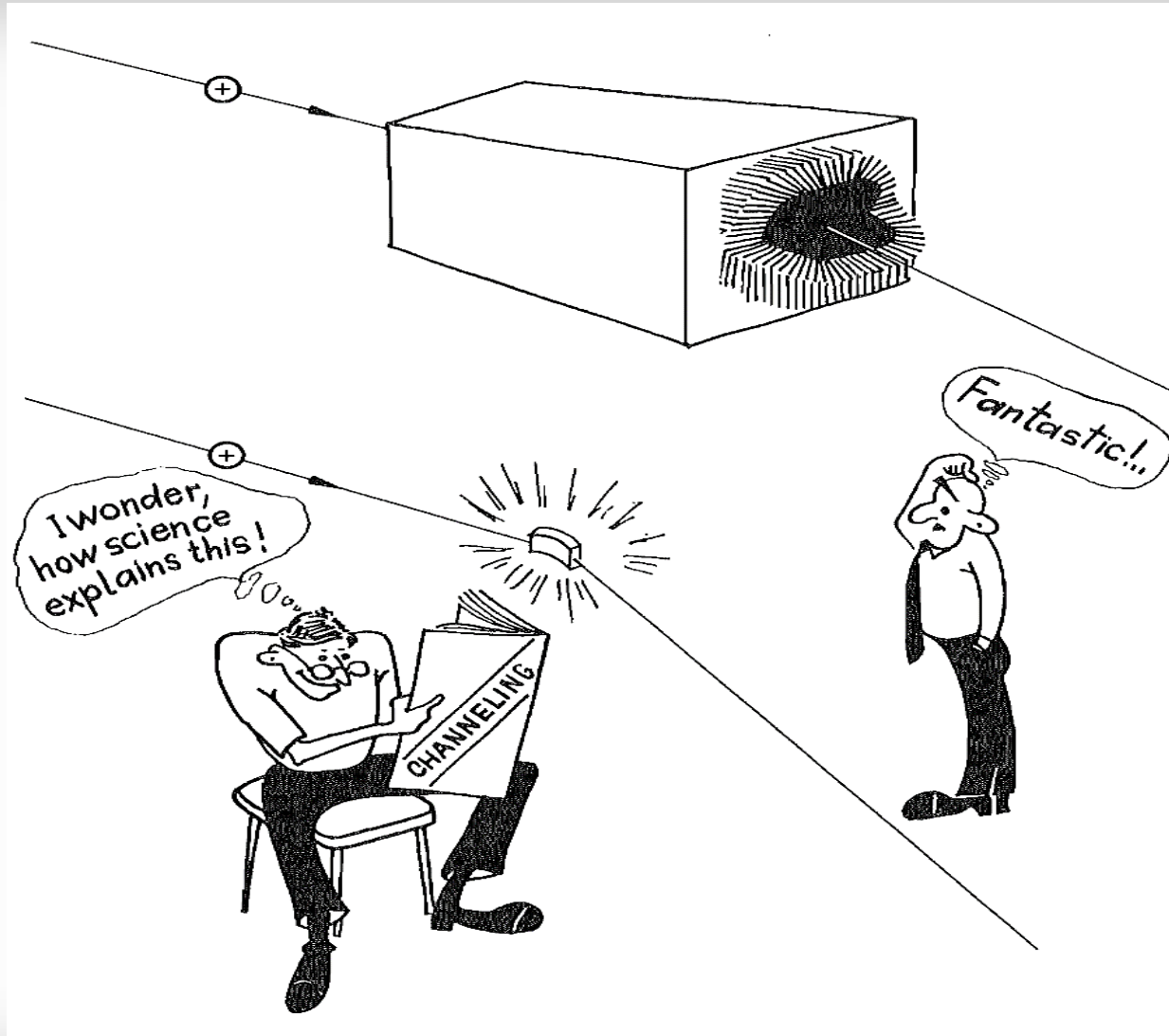

Crystal-based extraction: the idea

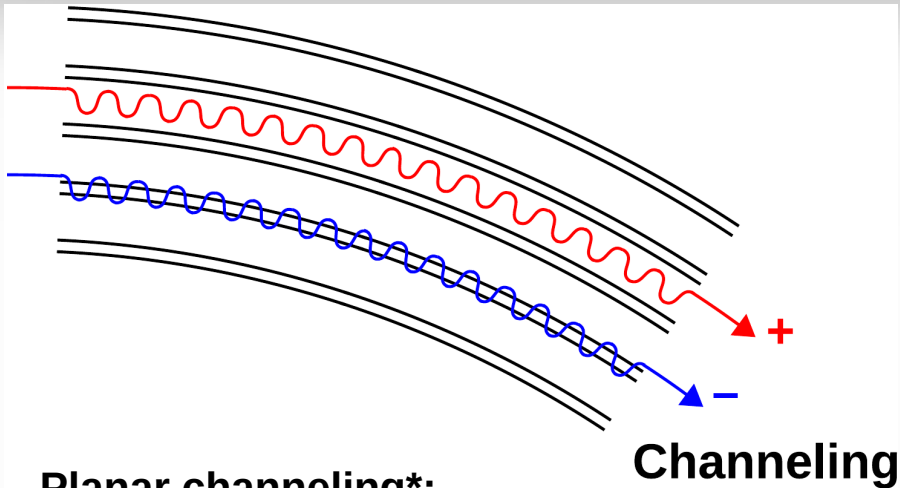

Planar channeling*:

● Charge particle penetration through a monocrystal along its atomic planes

Crystal-based extraction/collimation

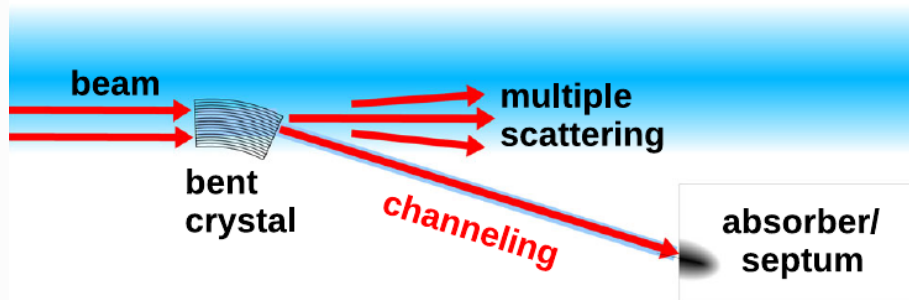

Crystal-based collimation and extraction have been used at hadron machines

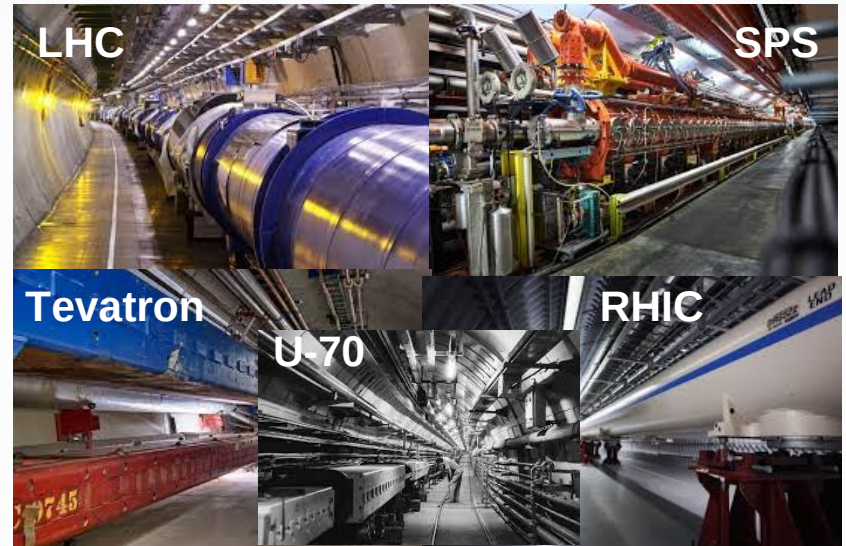

Crystal-based extraction/collimation: applied only for hadrons, not yet for e-

Interesting for tens of electron synchrotrons



*J. Lindhard, Kgl. Dan. Vid. Selsk. Mat.-Fys. Medd. 34 No 4, 2821–2836 (1965)

E.N. Tsyganov, Fermilab TM-682 (1976)

A. Sytov et al. Eur. Phys. J. C 82, 197 (2022)

Crystal-based extraction: possible setup at DESY-II

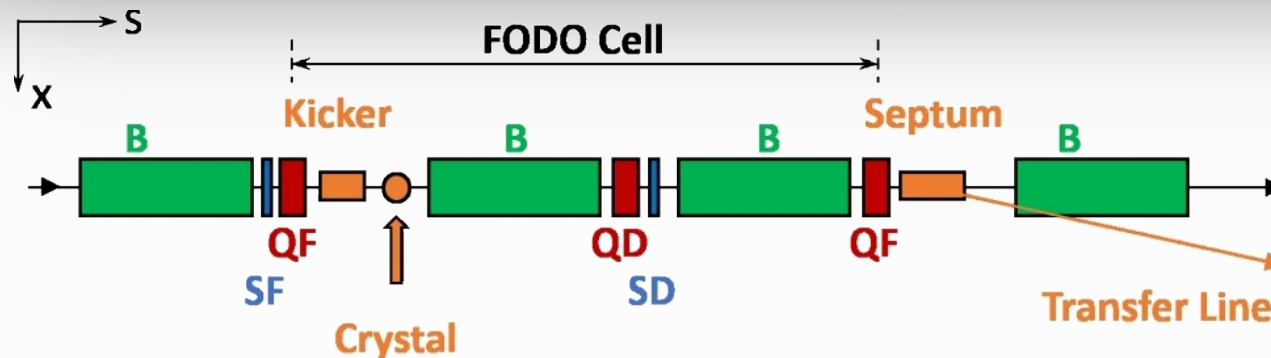

B->dipoles
QF/QD->focusing/
defocusing quadrupoles

6 GeV electrons

Advantages:

- Extraction of **primary** low-emittance and very **intense electron beam** in a **parasitic mode**.
- The **extraction line** including septum magnets already **exists** => **ideal for prove-of-principle**
- **Few GeV** electron beam, **typical** for **synchrotron light sources** existing in the world.

Applications:

- Nuclear and particle physics detectors and generic **detector R&D**
- Fixed-target experiments in **high-energy physics** including future **lepton colliders**
- Also: **crystal-based collimation** (synchrotron light sources, colliders)

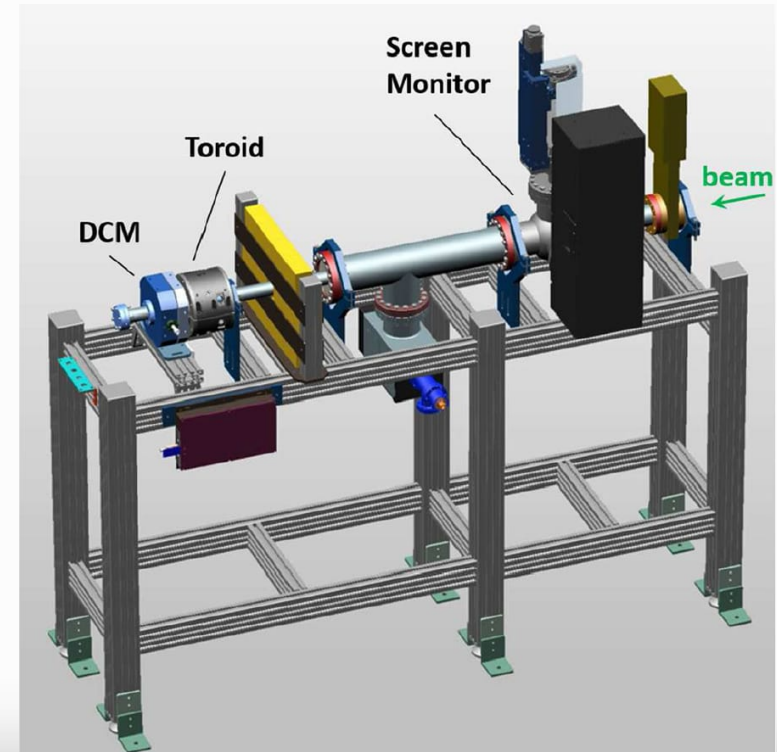

Steering of a Sub-GeV electron beam using new generation of crystals @INFN Ferrara

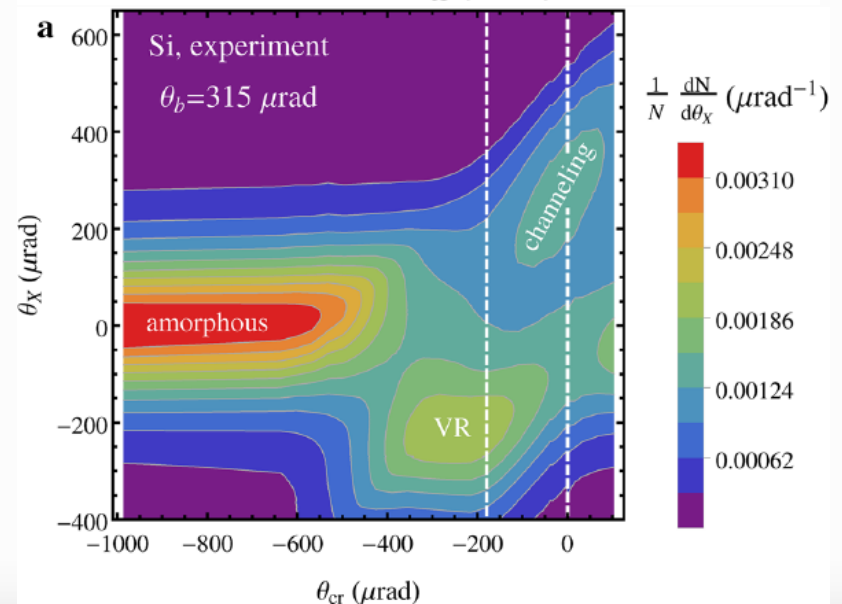
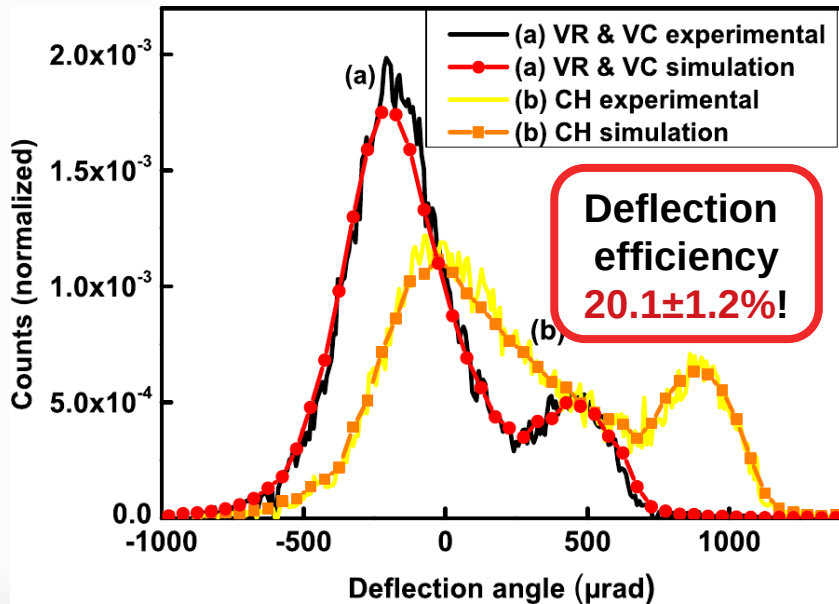
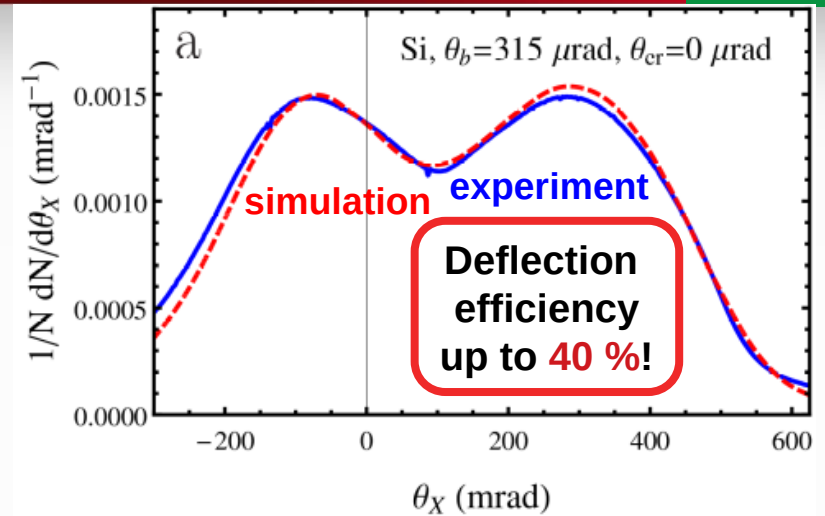
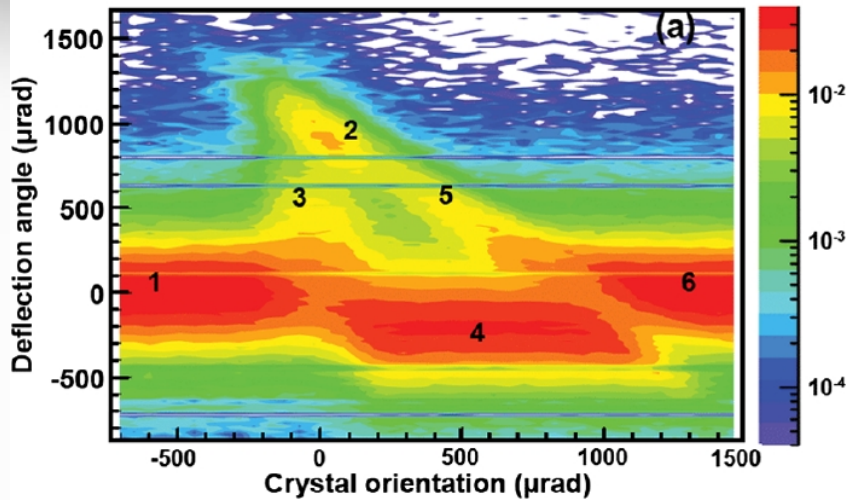

A.I. Sytov, L. Bandiera et al. Eur. Phys. J. C 77, 901 (2017)

A. Mazzolari et al. PRL 112, 135503 (2014)

Manufacturing and characterization of bent silicon crystals @INFN Ferrara

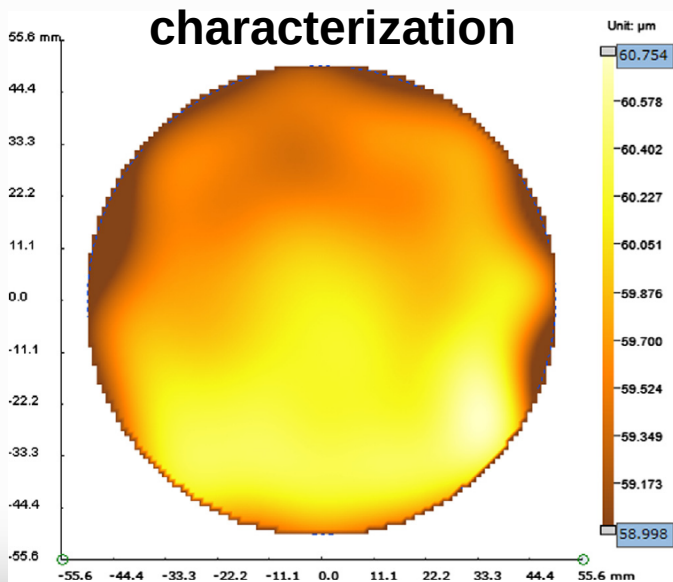
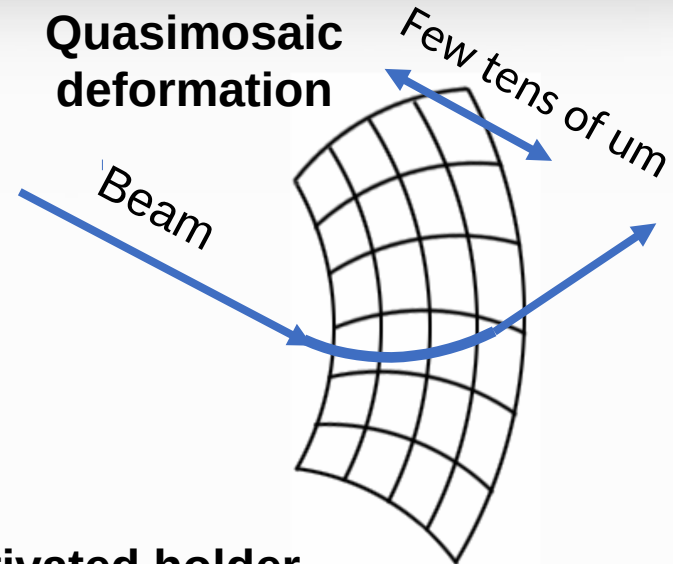

Piezo-activated holder

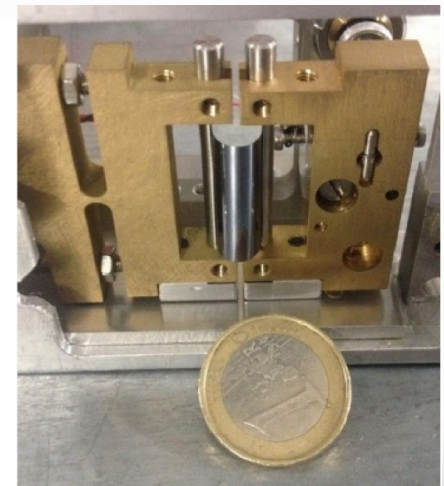
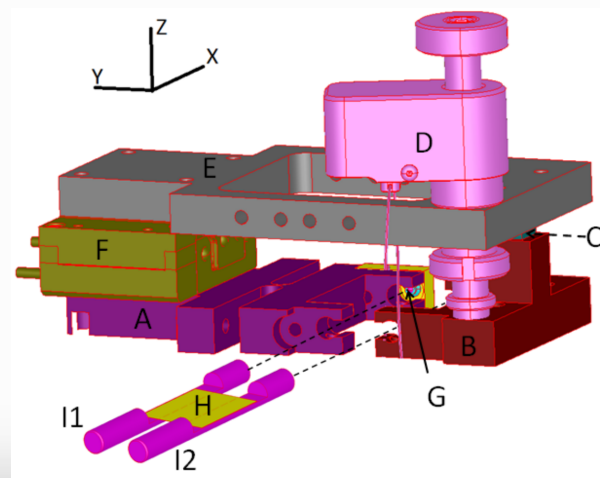

Experimental setup at Mikrotron MAMI

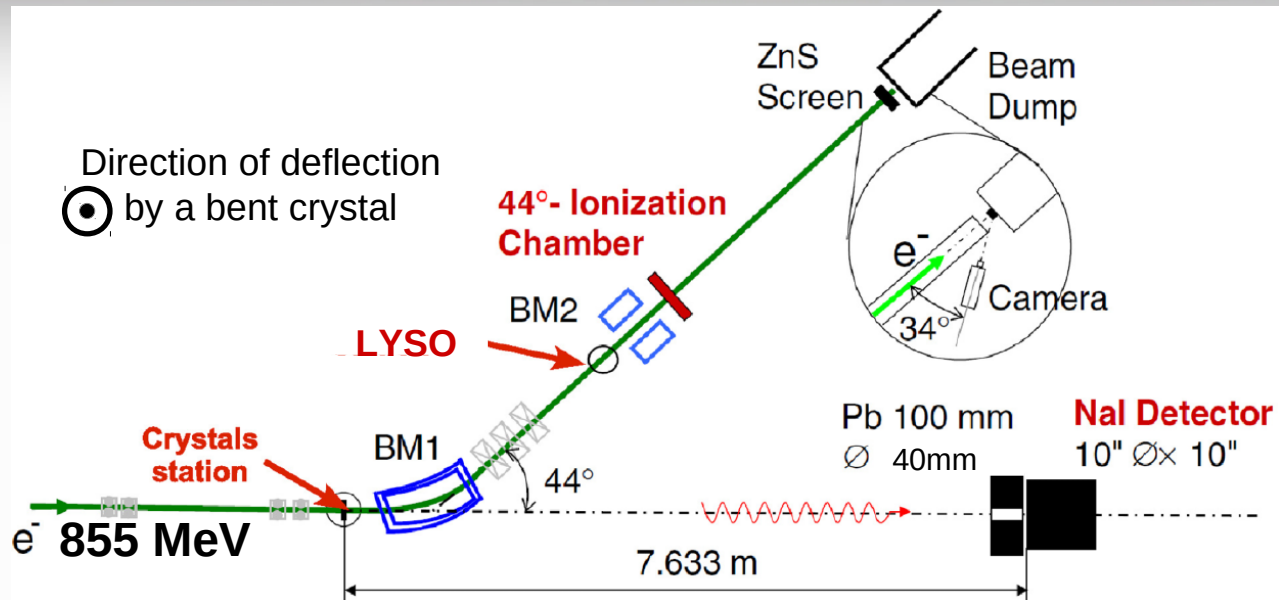

Crystal station

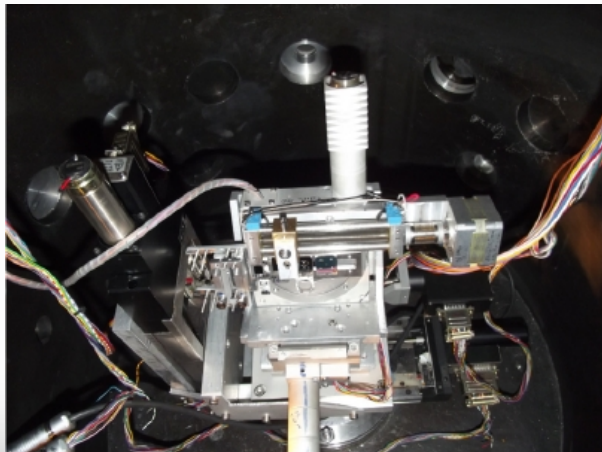

Detector station

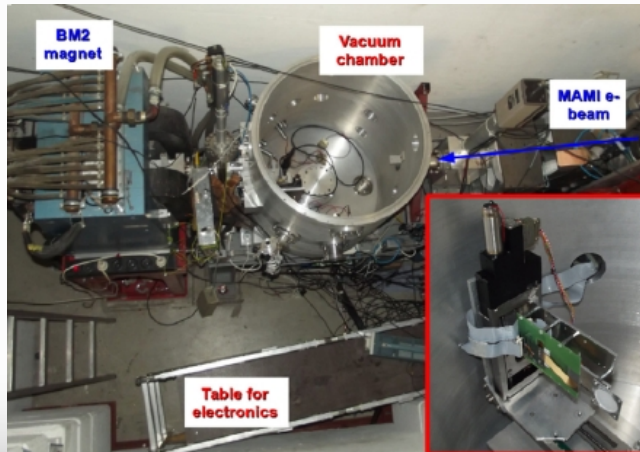

Crystal characterization: simulations of the deflection of 855 MeV electrons at Mainz Mikrotron MAMI

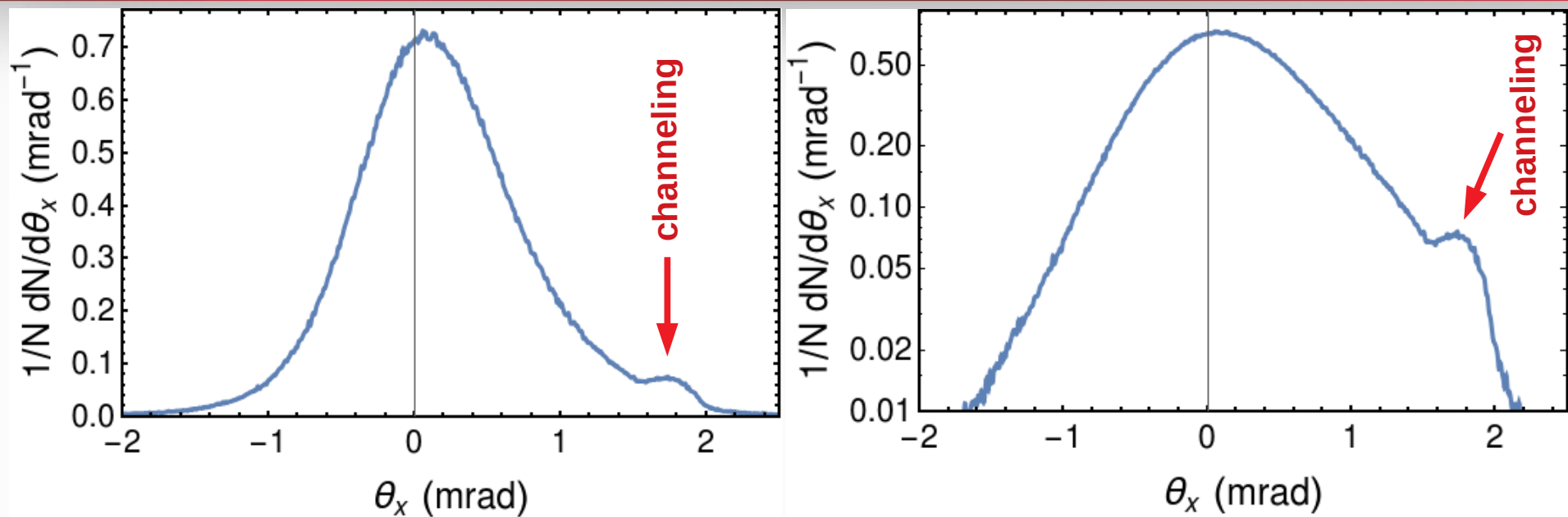

LYSO screen photo example

channeling

Simulation parameters:

- 855 MeV electrons
- Si (111)
- bending angle 1.75 mrad
- Crystal length 0.175 mm

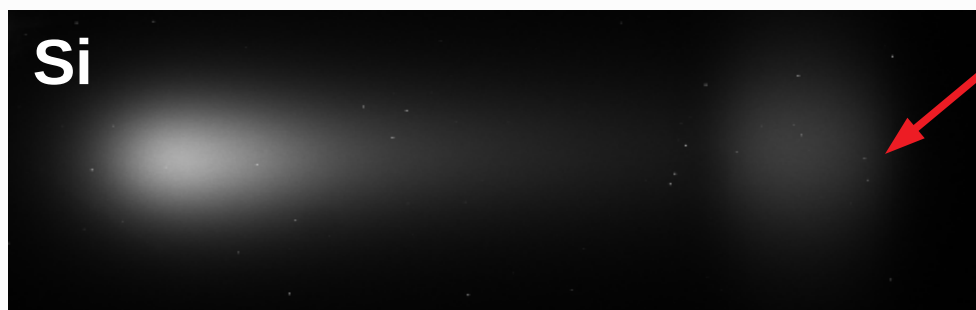

A.I. Sytov, L. Bandiera et al. Eur. Phys. J. C 77, 901 (2017)

D. De Salvador et al. JINST 13, C04006 (2018)

A. Mazzolari, A.I. Sytov, et al. Eur. Phys. J. C 80, 63 (2020)

CRYSTALRAD simulation code*

Main conception – tracking of charged particles in a crystal in averaged atomic potential

Program modes:

- **1D** model – particle motion in an interplanar potential
- **2D** model – particle motion in an interaxial potential

Simulation of the different physical processes:

- Multiple and single **Coulomb scattering** on nuclei and electrons.
- **Nuclear scattering**
- **Ionization energy losses**
- **Crystal geometry**



Multiturn simulations** taking into account both **betatron** and **synchrotron oscillations** with **radiation losses** in a **crystal**

Simulation of **radiation losses** by Baier-Katkov formula

Advantages:

- High calculation speed (up to **10³ particles/s/core**)
- **MPI** parallelization for high performance computing

Marie Curie Marie Skłodowska-Curie Action Global Fellowships by A. Sytov in 2021-2024, Project **TRILLION**

Dedicated supercomputer time at CINECA:
project **LEADER** and **MIRACLE** Cineca ISCRA Class B

*A.I. Sytov, V.V. Tikhomirov and L. Bandiera Phys. Rev. Acc. and Beams 22, 064601 (2019)

**A. I. Sytov, V. V. Tikhomirov, and A. S. Lobko. Phys. Rev. Acc. and Beams 20, 071001 (2017)

Setup for simulations and beam at the crystal entrance

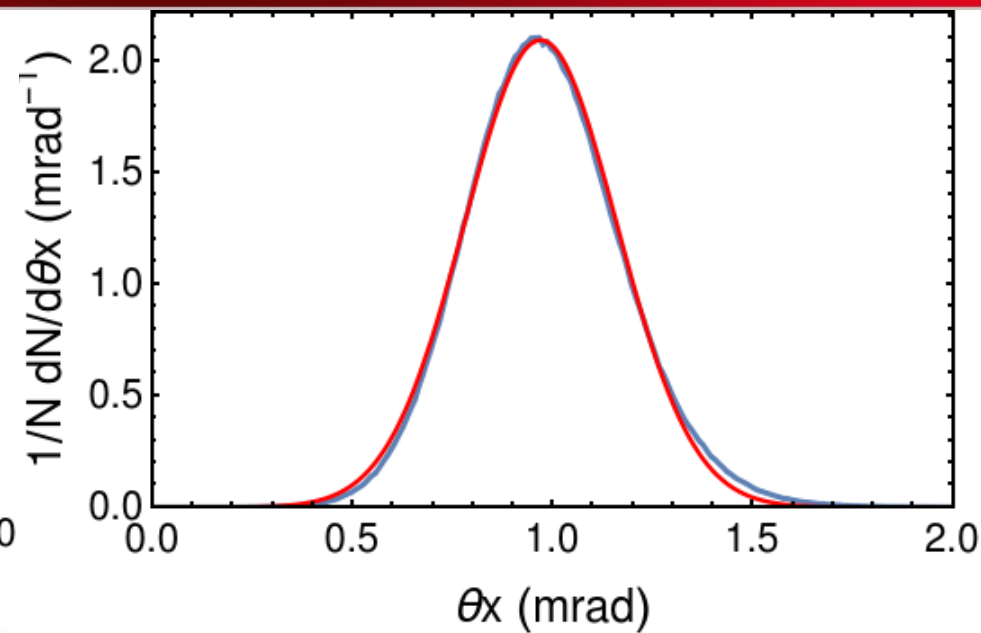
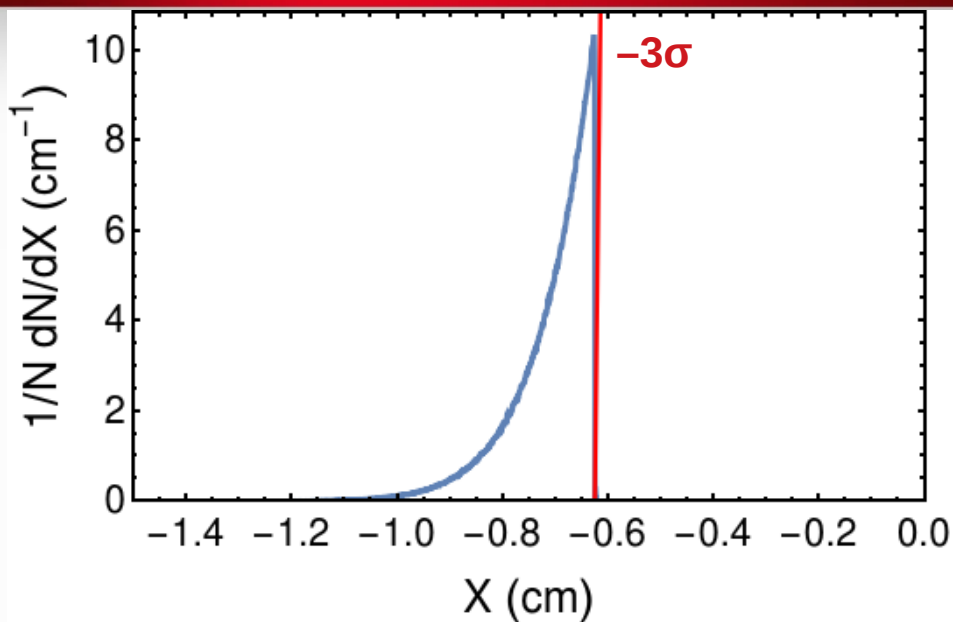

Beam Parameters:

- $\epsilon_x = 339$ nm, $\epsilon_y = 35$ nm, $\sigma_e/E = 0.977e-3$, $E = 6$ GeV
- $\sigma = \sqrt{\beta\epsilon_x}$ (betatron sigma)
- $x_{\text{crystal}} = -3\sigma$, $x_{\text{septum}} = 4\sigma$

Cuts for the extracted beam:

- $x > 4\sigma = 0.98$ cm
- -4 mrad $< \theta_x < 0$ mrad
- $E = 6.0 \pm 0.1$ GeV
- $N_{\text{turns}} = 100$

Beam **angular divergence** at the crystal entrance: **0.18 mrad**

Critical channeling angle:
0.07 mrad (Si, (111))

Optimal alignment at -3σ :
0.97 mrad

Simulated angular distributions of deflected beam

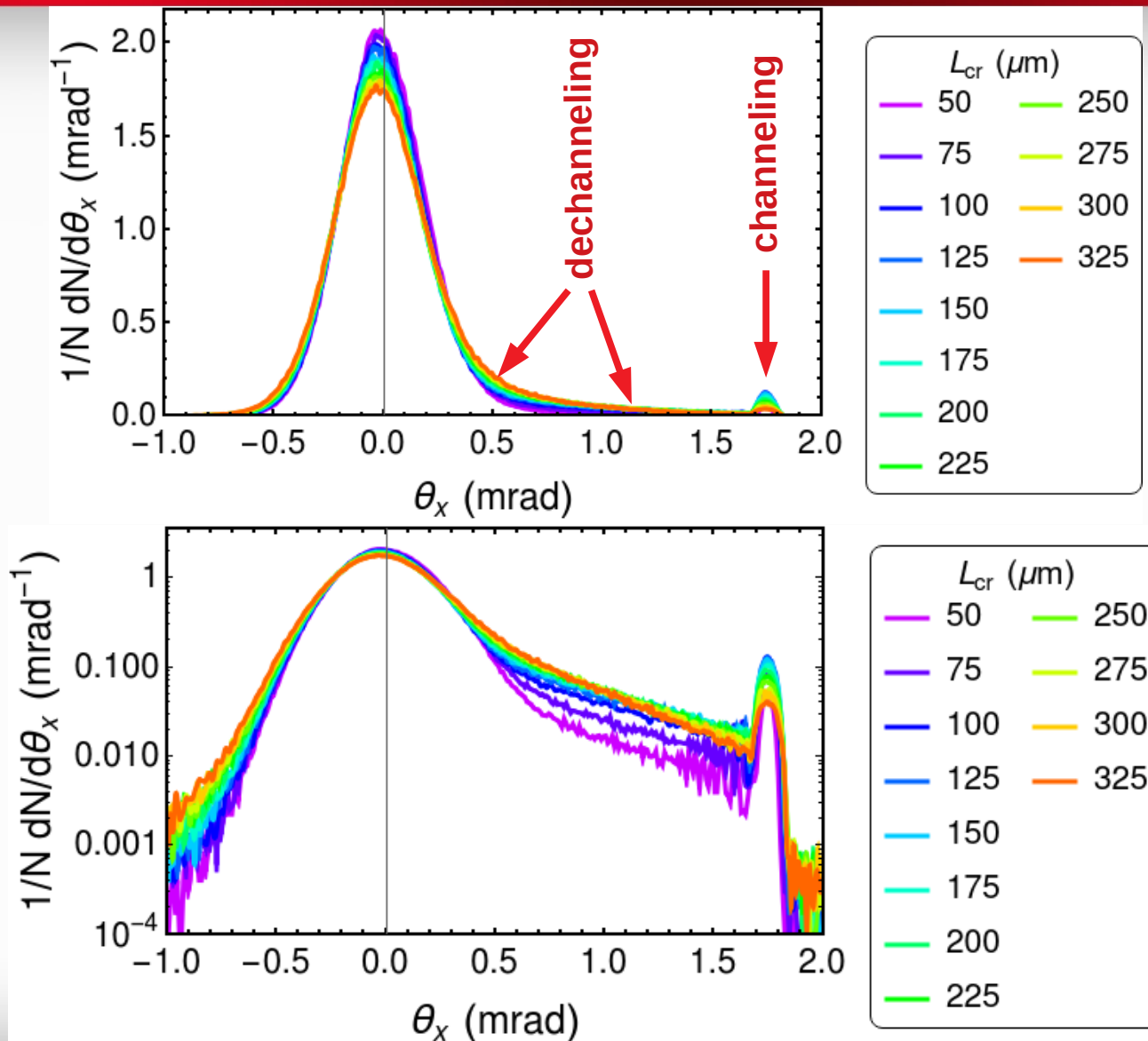

Crystal-based extraction simulations: energy losses

Radiation spectrum

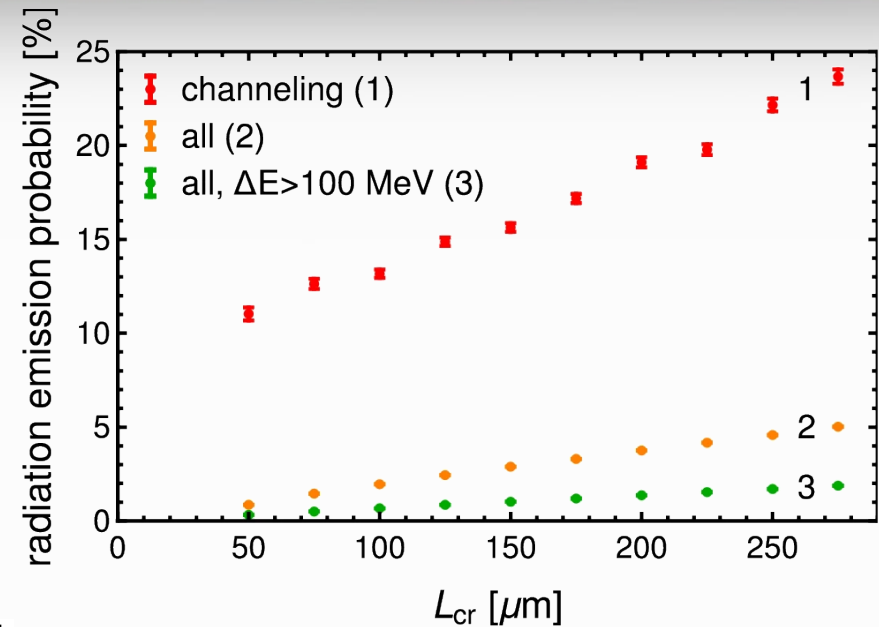
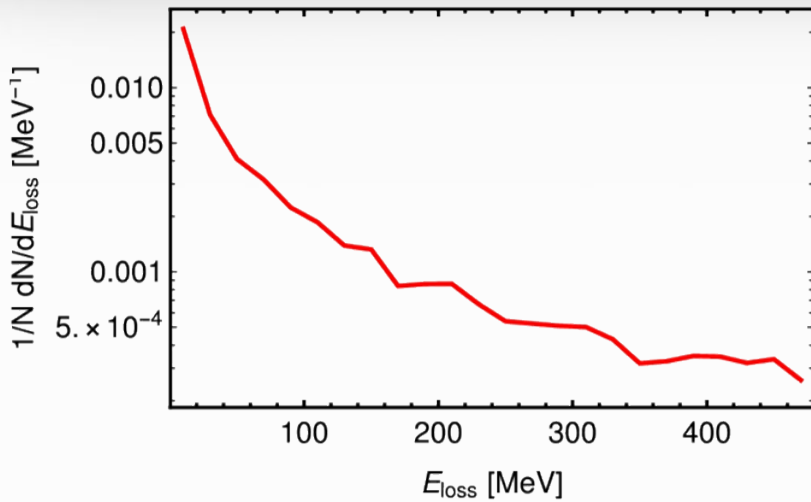

Energy distribution of the extracted beam

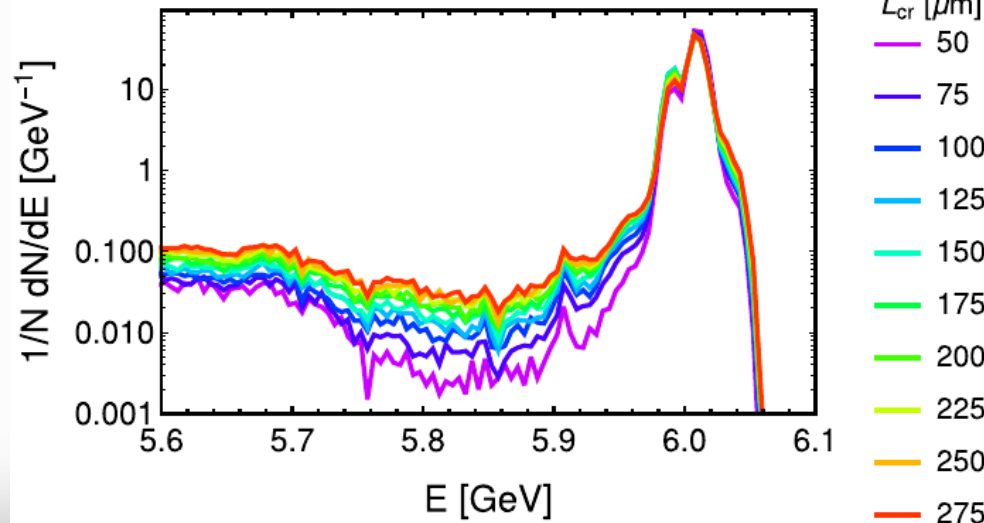

Radiation emission probability as function of the crystal thickness for **(red)** channeled particles, for **(yellow)** all particles and for **(green)** particles with radiation energy losses exceeding 100 MeV.

Energy remains within **RF bucket**

Crystal-based extraction: simulation results

Coordinate distribution of extracted beam

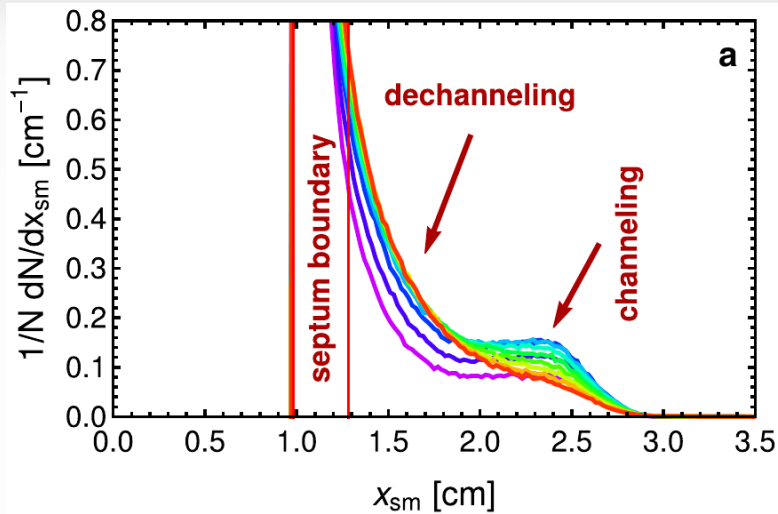

Angular divergence of extracted beam

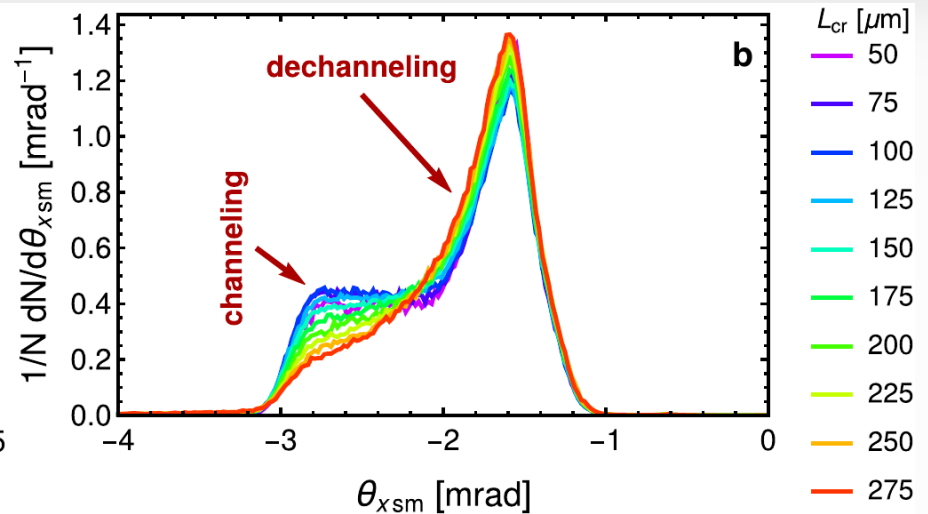

Extraction efficiency

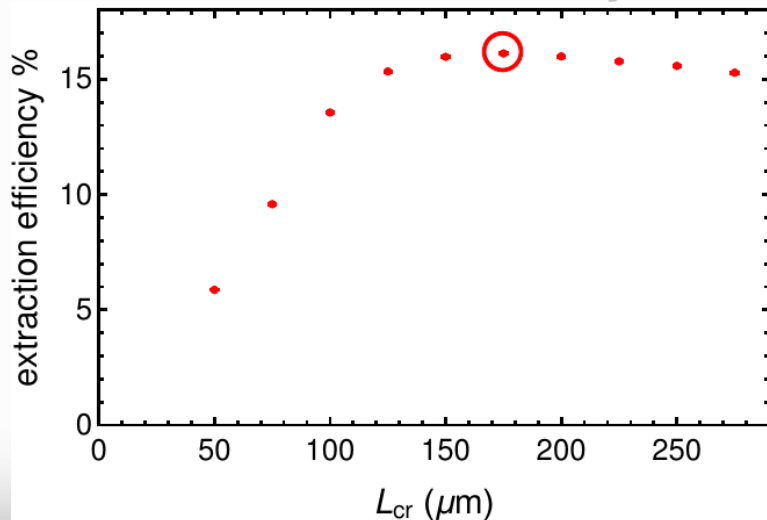

Crystal parameters:

- Si (111)
- bending angle **1.75 mrad**
- Crystal length **0.175 mm**
- Crystal transverse thickness **1 cm**

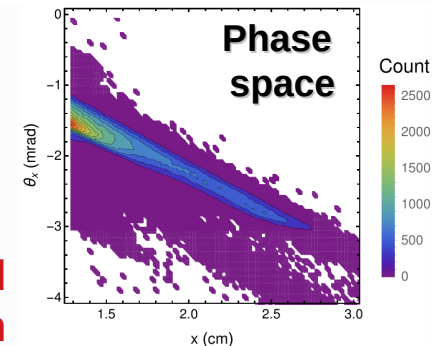

Maximal extraction efficiency:
16.1 %

Marie Skłodowska-Curie Action Global Individual Fellowships by A. Sytov in 2021-2024, Project TRILLION GA n. 101032975

Main goal: The **implementation** of both physics of **electromagnetic processes in oriented crystals** and the design of specific applications of crystalline effects into **Geant4** simulation toolkit as Extended Examples to bring them to a large scientific and industrial community and under a free Geant4 license.

Group:

- **A. Sytov** – project coordinator
- **L. Bandiera** – INFN supervisor
- **K. Cho** – KISTI supervisor
- **G. Kube** – DESY supervisor
- **I. Chaikovska** – IJCLab Orsay supervisor

Location:

- 2 years at **KISTI** (partner organization)
- 1 year at **INFN Section of Ferrara** (host organization)
- 1 month of secondment at **DESY** (partner organization)
- 1 month of secondment at **IJCLab Orsay** (partner organization)



In the future:
**Crystal-based
extraction from the
DESY II synchrotron
as a Geant4 example**

**More details in
my poster PU-9**

Conclusions

- The **first proof-of-principle experiment** on electron crystal-based extraction by using planar channeling in a bent crystal has been proposed for the **DESY II Booster Synchrotron**.
- The **extraction** line already **exists**, only a bent crystal should be installed.
- Simulations of the DESY crystal-based extraction show that the multiturn extraction efficiency may reach **16 %**.
- Crystal thickness was optimized to be **0.175 mm** for the deflection angle **1.75 mrad**.

Applications:

- Nuclear and particle physics detectors and generic **detector R&D**
- **Fixed-target experiments** in **high-energy physics** including future **lepton colliders**
- Also: **crystal-based collimation** (synchrotron light sources, colliders)

Where the crystal-based extraction of electrons can be applied?



Where the crystal-based extraction of electrons can be applied?

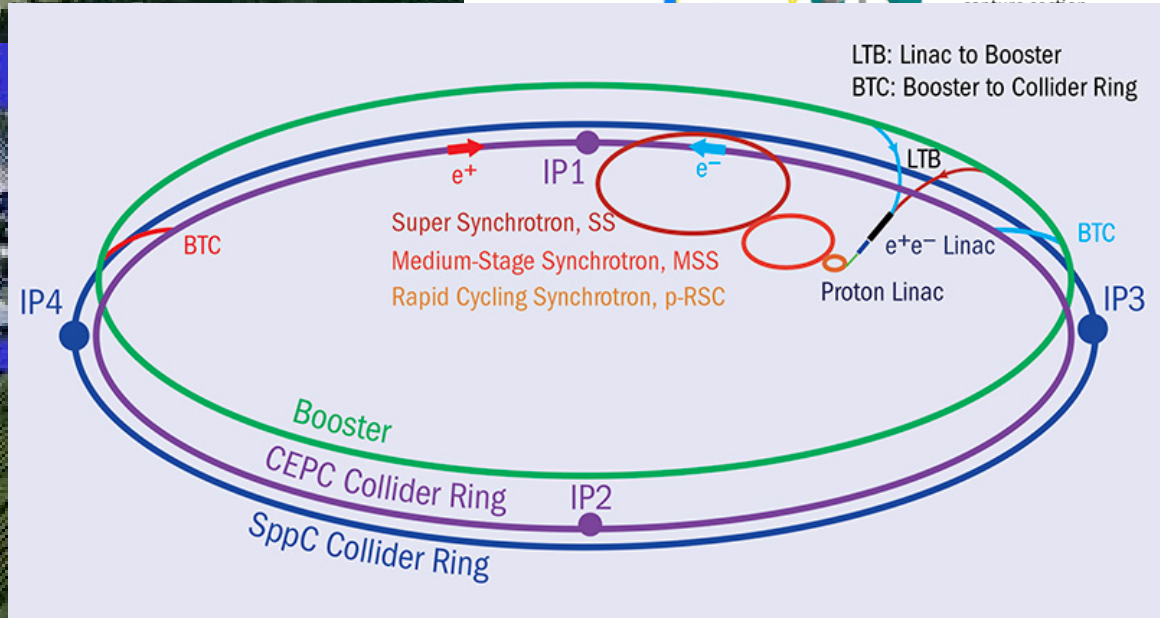
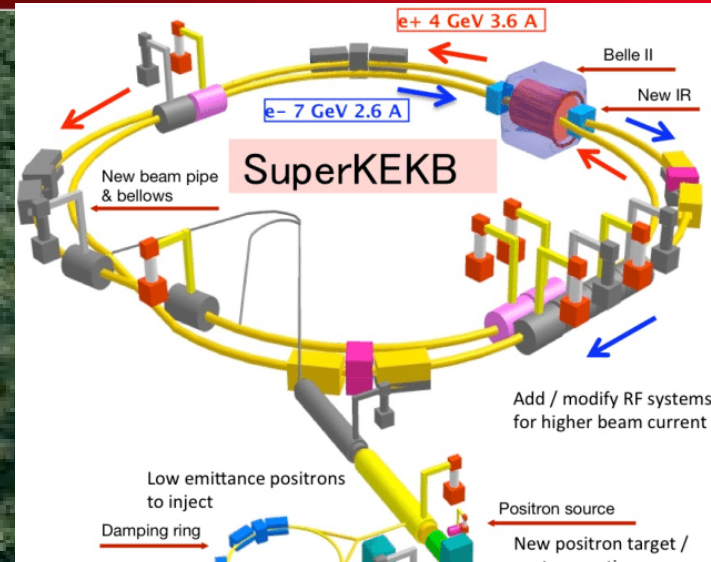

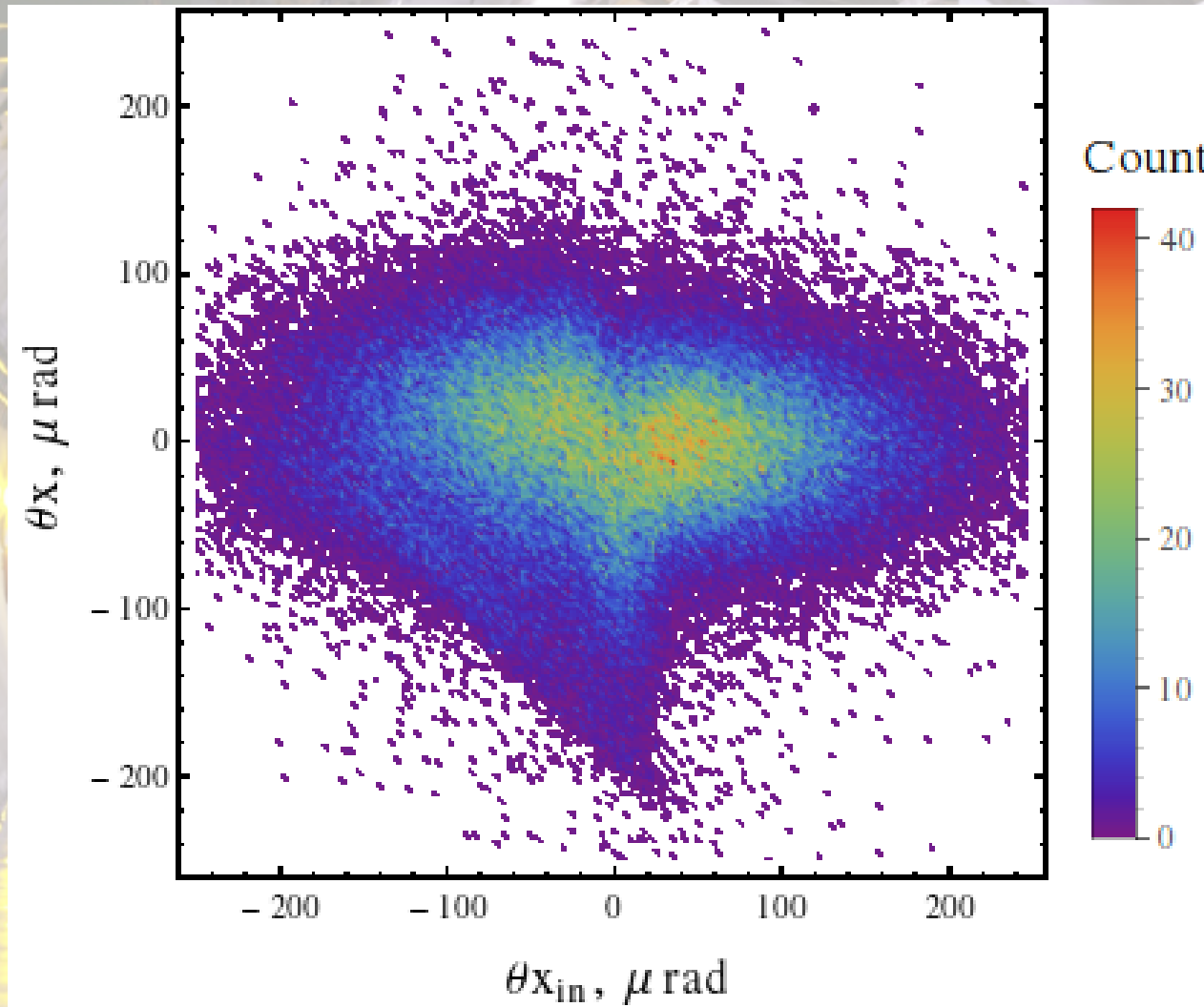

Thank you for attention!

Applications*

Crystal-based collimation or beam extraction from an accelerator

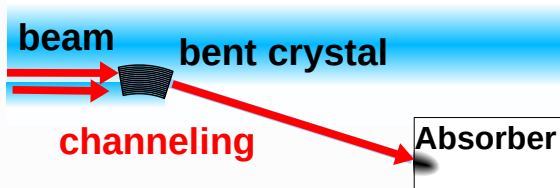

Measurement of dipole magnetic and electric moments of exotic particles

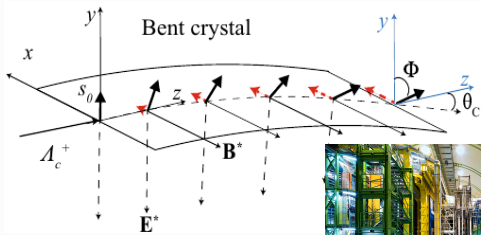

Ultrashort crystalline calorimeter

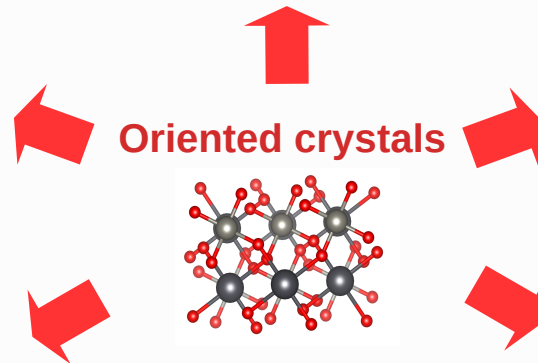
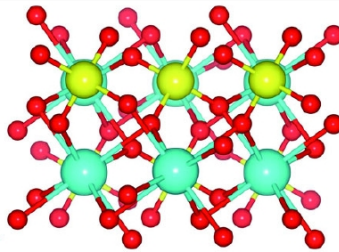

Plasma acceleration

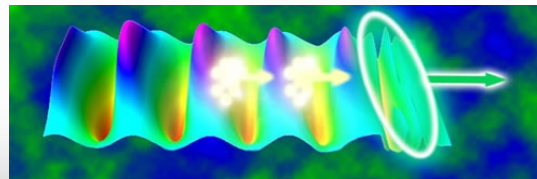

Positron source for future e+/e- and muon colliders

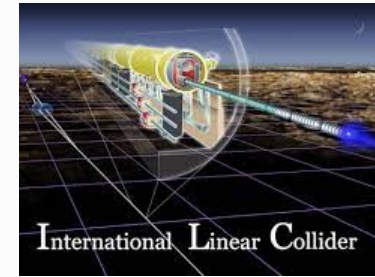
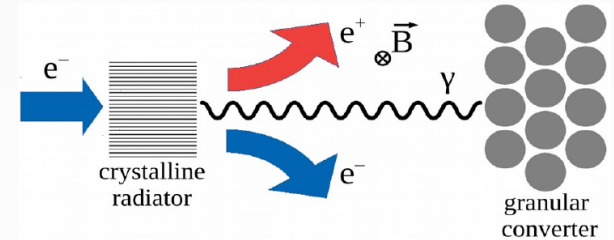

X and gamma-ray source for nuclear and medical physics

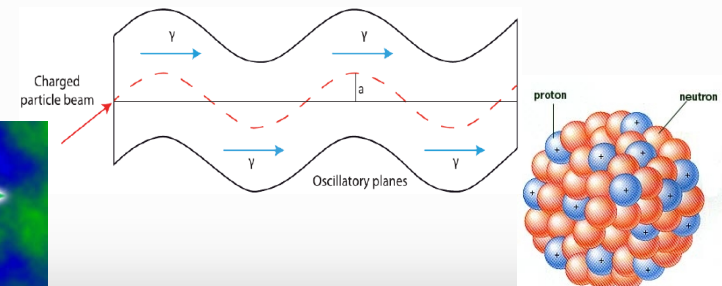

Crystal-based extraction: the idea

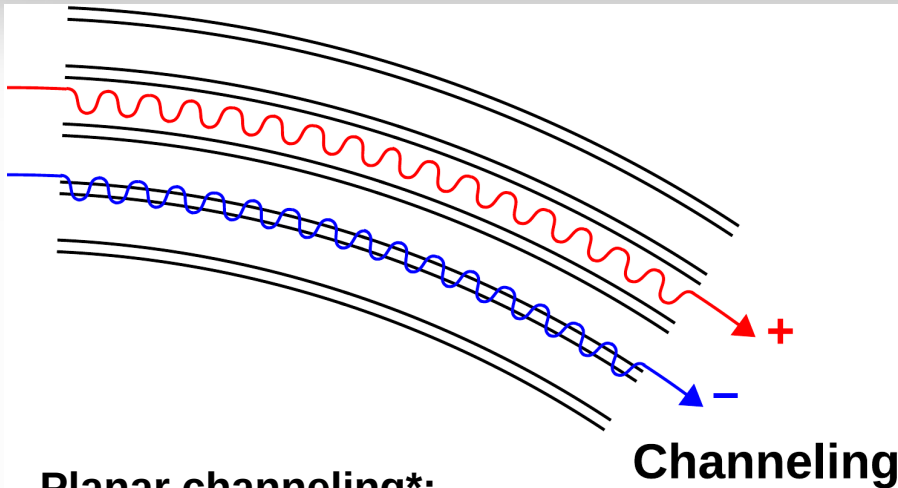

Planar channeling*:

● Charge particle penetration through a monocrystal along its atomic planes

Crystal-based extraction**

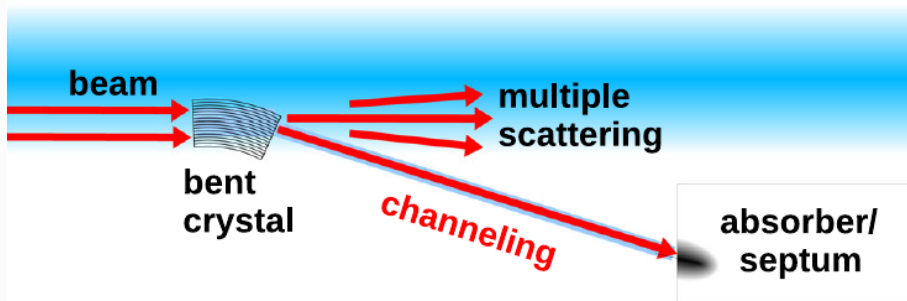

Interplanar potential

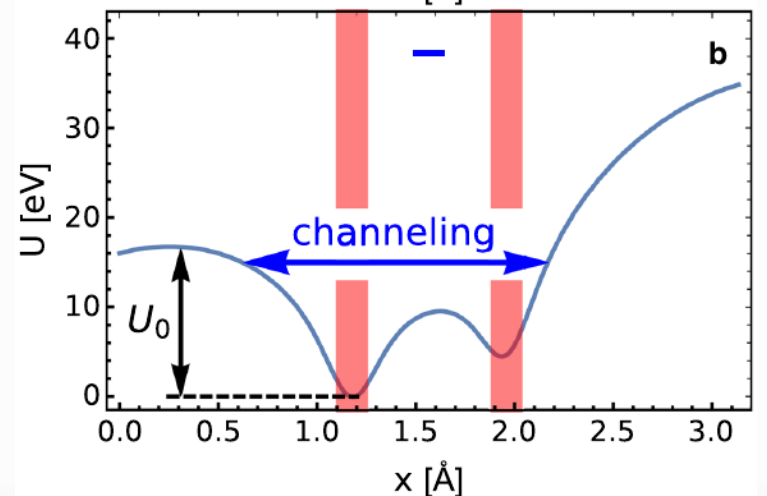
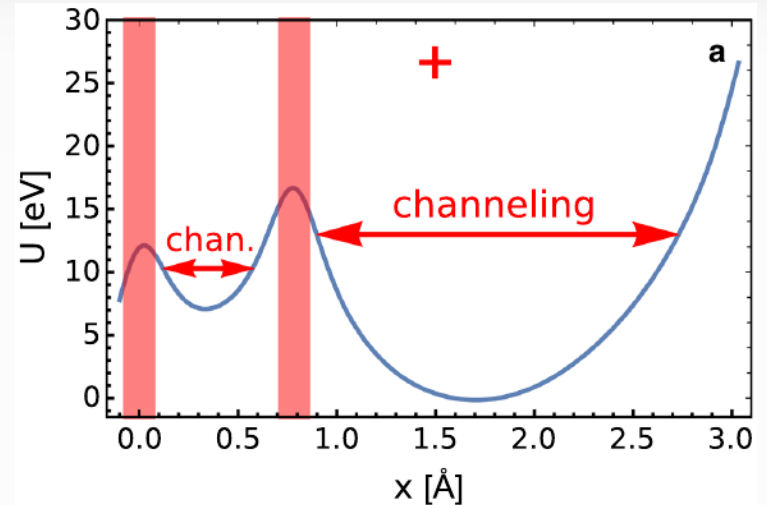

*J. Lindhard, Kgl. Dan. Vid. Selsk. Mat.-Fys. Medd. 34 No 4, 2821–2836 (1965)
E.N. Tsyganov, Fermilab TM-682 (1976)

**A. Sytov et al., Eur. Phys. J. C (2022) 82:197